



KARTA: .....

Z KLASY: .....

## Czym chcę podróżować?

1 Ponumeruj obrazki tak, aby powstała historyjka.



2 Wymyśl tytuł dla historyjki z zadania 1.



KAPITAŁ LUDZKI  
NARODOWA STRATEGIA SPÓJNOŚCI



OŚRODEK  
ROZWOJU  
EDUKACJI



UNIA EUROPEJSKA  
EUROPEJSKI  
FUNDUSZ SPOŁECZNY



KARTA: .....

Z KLASY: .....



- 3 Otocz niebieską pętlą te pojazdy, które mogą się poruszać po wodzie, a czerwoną pętlą – te pojazdy, które mogą się poruszać po śniegu. Policz, których pojazdów jest więcej.

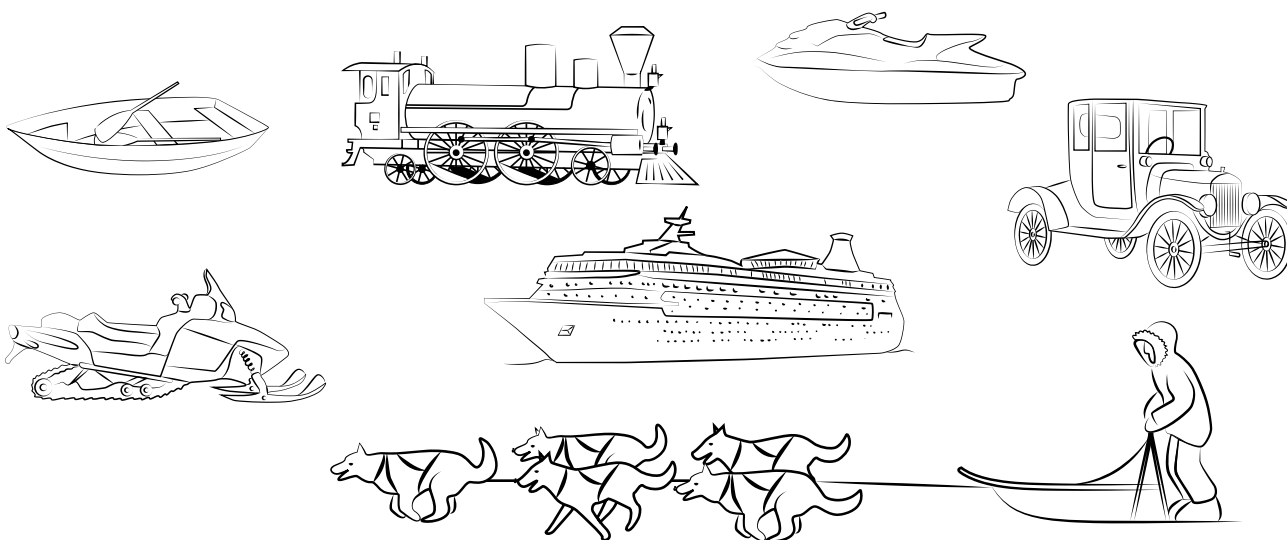

- 4 Dorysuj w każdym prostokącie tyle elementów, aby razem było ich pięć.

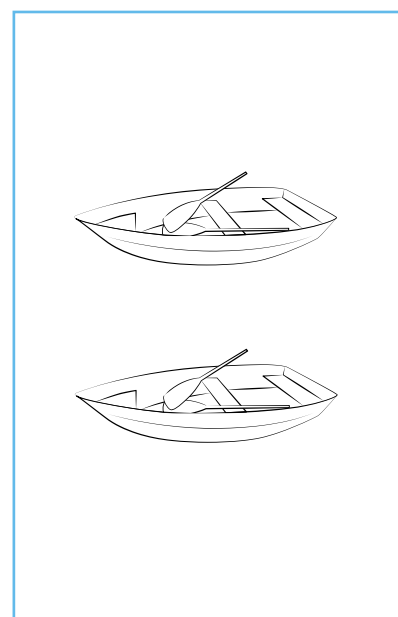
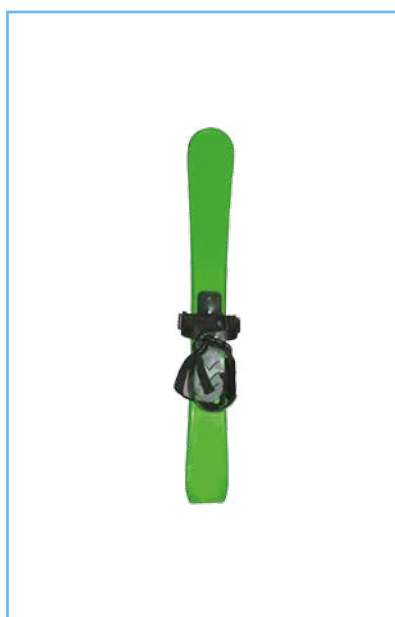
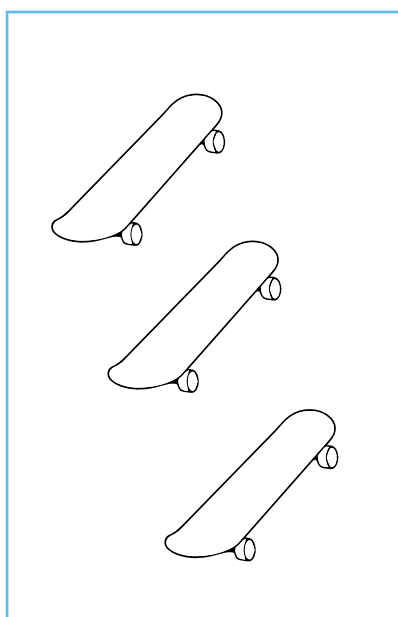



KARTA: .....

Z KLASY: .....

## Czym chcę podróżować?



1 Napisz po śladzie cyfrę pięć.



2 Policz wszystkie pojazdy pokazane na rysunku.



3 Otocz pętlami urządzenia służące człowiekowi do przemieszczania się, a następnie policz je.





KARTA: .....

Z KLASY: .....

4 Narysuj w pętli pięć różnych figur geometrycznych.

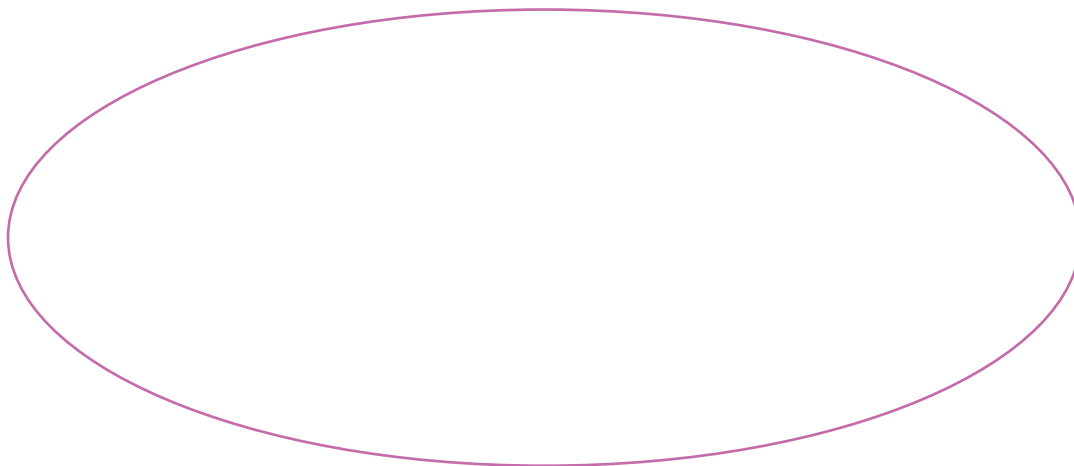

5 Pokoloruj samochody:

- na niebiesko piąty samochód od prawej strony,
- na żółto piąty samochód od lewej strony.

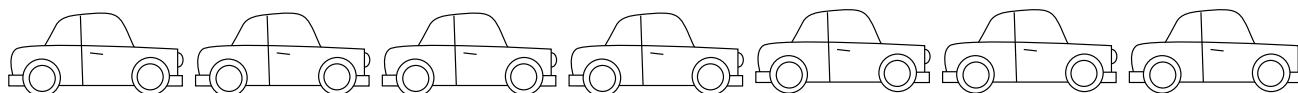

6 Powiedz, jak nazywa się piąty pojazd. Podaj nazwy pojazdów znajdujących się przed nim i za nim.

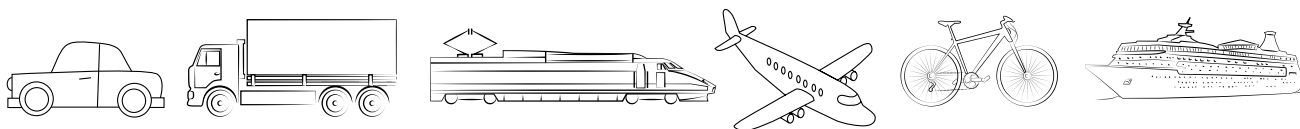

7 Wytnij starannie pasek.





KARTA: .....

Z KLASY: .....



## Colourful numbers

- 1** Listen and sing. Posłuchaj i zaśpiewaj.

One is **yellow**  
 Two is **blue**  
 Three is **green**  
 Four and five are **pink!**  
 Six is **purple**  
 Seven is **red**  
 Eight is **brown**  
 Nine and ten are **black!**

- 2** Colour. Pokoloruj.

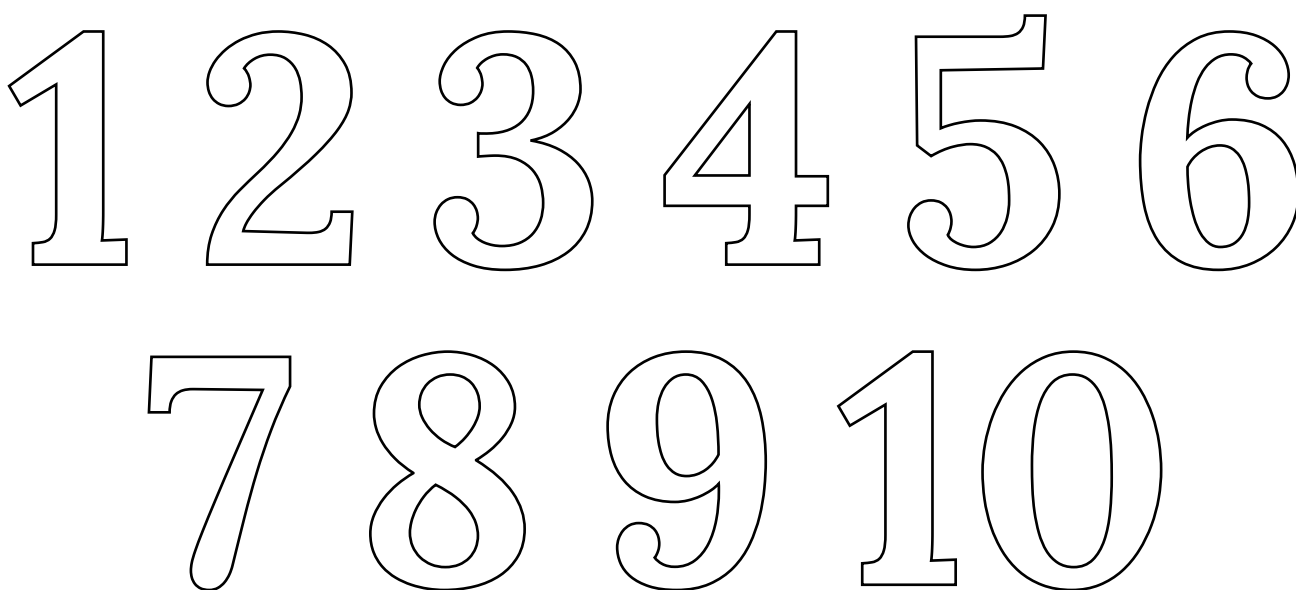

KAPITAŁ LUDZKI  
NARODOWA STRATEGIA SPÓJNOŚCI



OŚRODEK  
ROZWOJU  
EDUKACJI



UNIA EUROPEJSKA  
EUROPEJSKI  
FUNDUSZ SPOŁECZNY





KARTA: .....

Z KLASY: .....



3 Write. Napisz.

one two three four five

six seven eight nine ten

4 Listen, match and colour. Posłuchaj, dopasuj i pokoloruj.

6 7 8 9 10

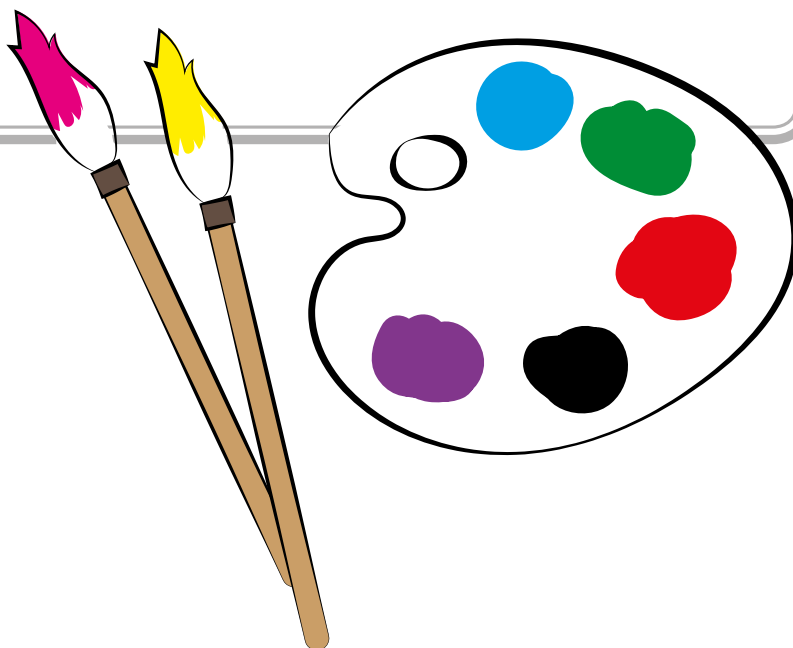



KARTA: .....

Z KLASY: .....

**1** Look and write. Popatrz i napisz.one is  yellowtwo is  bluethree is  greenfour and five are  pink!six is  purpleseven is  redeight is  brownnine and ten are  black!**2** Read and match. Przeczytaj i połącz.

seven

nine

7

ten

6

8

10

eight

9

six

