



KARTA:

Z KLASY:

Odkrywamy tajemnice magnesu

- 1 Które magnesy będą się przyciągały? Napisz TAK przy odpowiednich rysunkach.

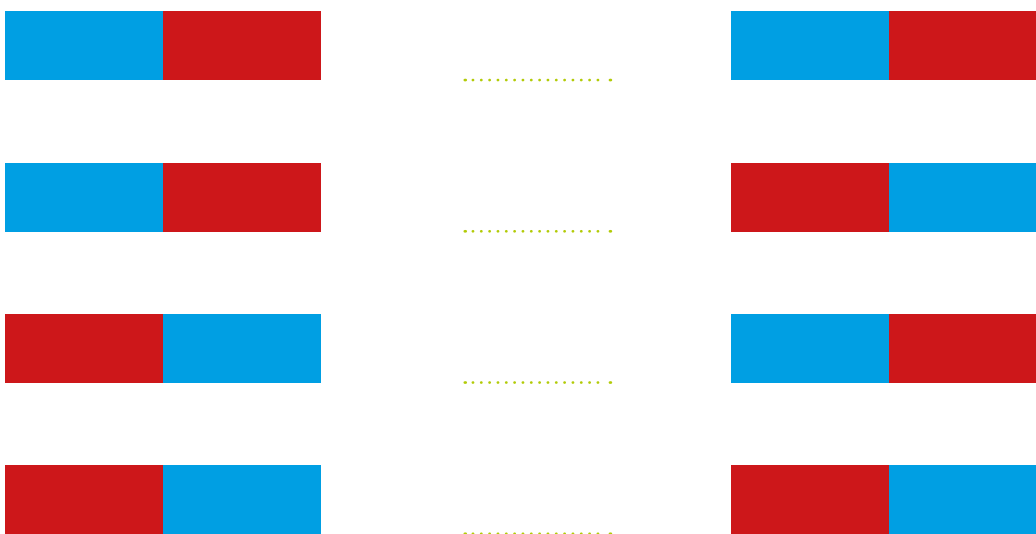

- 2 Na rysunku przedstawiono różę kierunków. Uzupełnij podpisy.

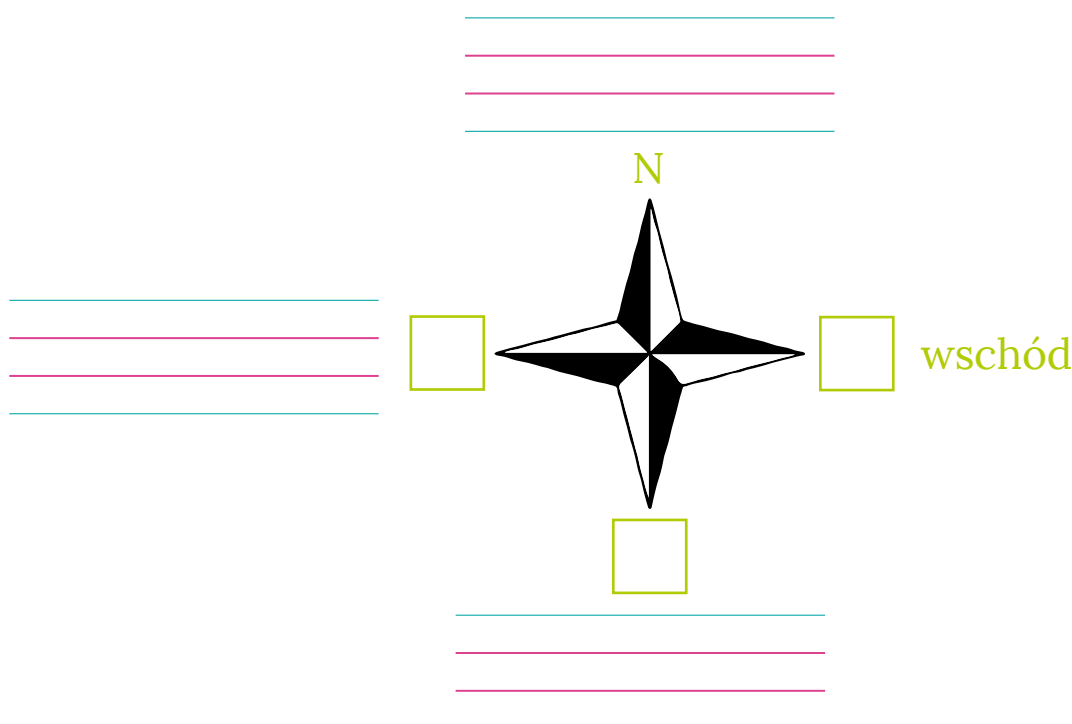



KARTA:

Z KLASY:

3 Który z pokazanych przyrządów służy do wyznaczania kierunków świata? Otocz go pętlą i zapisz jego nazwę.

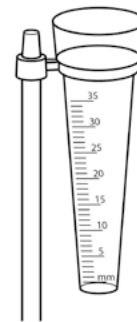
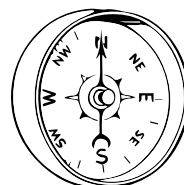
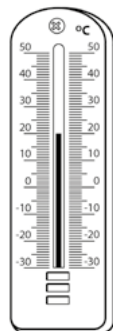
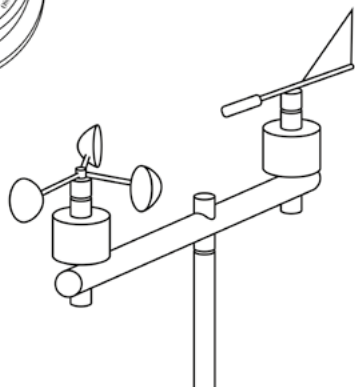

4 Otocz kółkiem P, jeśli informacja jest prawdziwa, lub F, jeśli jest fałszywa.

Mech porasta kamienie od strony północnej.	P	F
Gałęzie samotnie rosnącego drzewa są dłuższe i bardziej rozrośnięte od strony południowej.	P	F
Pnie ściętych drzew mają słoje węższe od strony północnej.	P	F
Pień drzewa jest bardziej porośnięty mchem od strony południowej.	P	F



KARTA:

Z KLASY:

2 Oblicz.

$\cdot 3$	
1	
	6
3	
	12
5	
$: 3$	

$\cdot 4$	
1	
2	
	12
	16
5	
$: 4$	

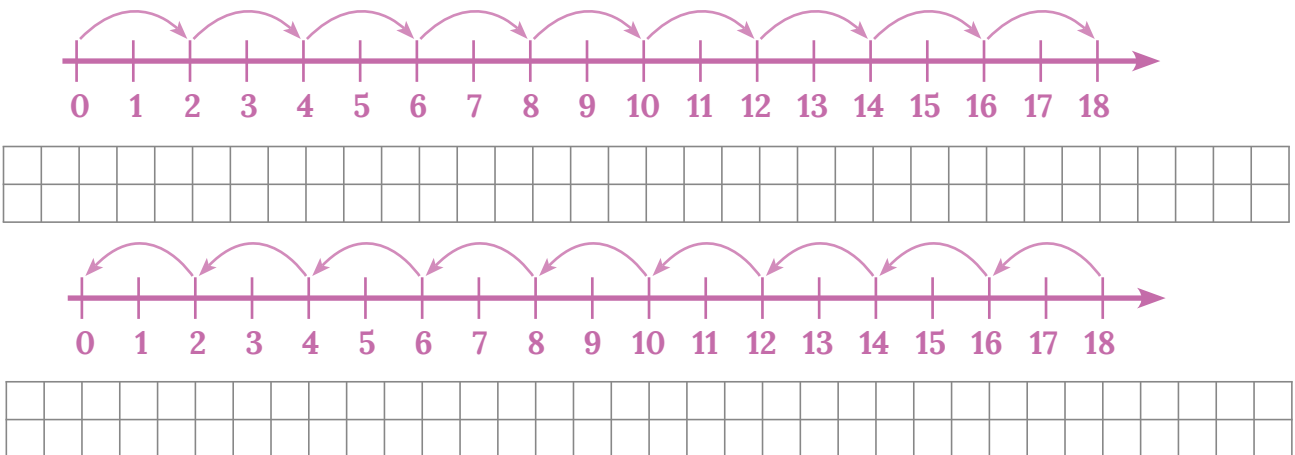

3 Porównaj wyniki za pomocą odpowiednich znaków.

$18 : 2$ $3 \cdot 3$
 $7 \cdot 4$ $21 : 3$
 $9 \cdot 3$ $30 : 5$



KARTA:

Z KLASY:



Do it yourself!

1 Listen and draw ☺ or ☹. Posłuchaj i narysuj ☺ lub ☹.

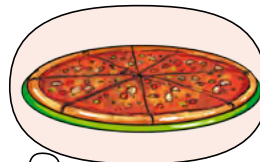

2 Read and complete the sentences. Use: **like** or **don't like**.
Przeczytaj i uzupełnij zdania. Użyj: **like** lub **don't like**.



I _____ rice.



I _____ tea.

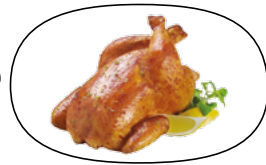

I _____ chicken.



I _____ juice.

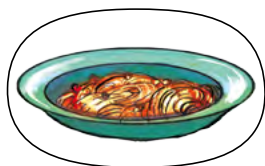

I _____ spaghetti.





KARTA:

Z KLASY:



3 Listen and circle. Posłuchaj i zakreśl.





KARTA:

Z KLASY:

Razem
z Rodzicami**Młody naukowiec**

Urządźcie zawody.

Potrzebne rzeczy: 2 magnesy (najlepiej neodymowe), 8 spinaczy biurowych, stół, kartka z labiryntem, stoper.**Opis:** Połóżcie kartkę z labiryntem na stole. Jedna osoba bierze 4 spinacze biurowe i kładzie je na początku labiryntu. Na umówiony sygnał osoba ta stara się przesuwać spinacze w labiryncie magnesem, który trzyma pod stołem. Druga osoba mierzy jej czas. Po wykonaniu zadania następuje zmiana. Wygrywa osoba, która szybciej pokona labirynt.

Przykład labiryntu:

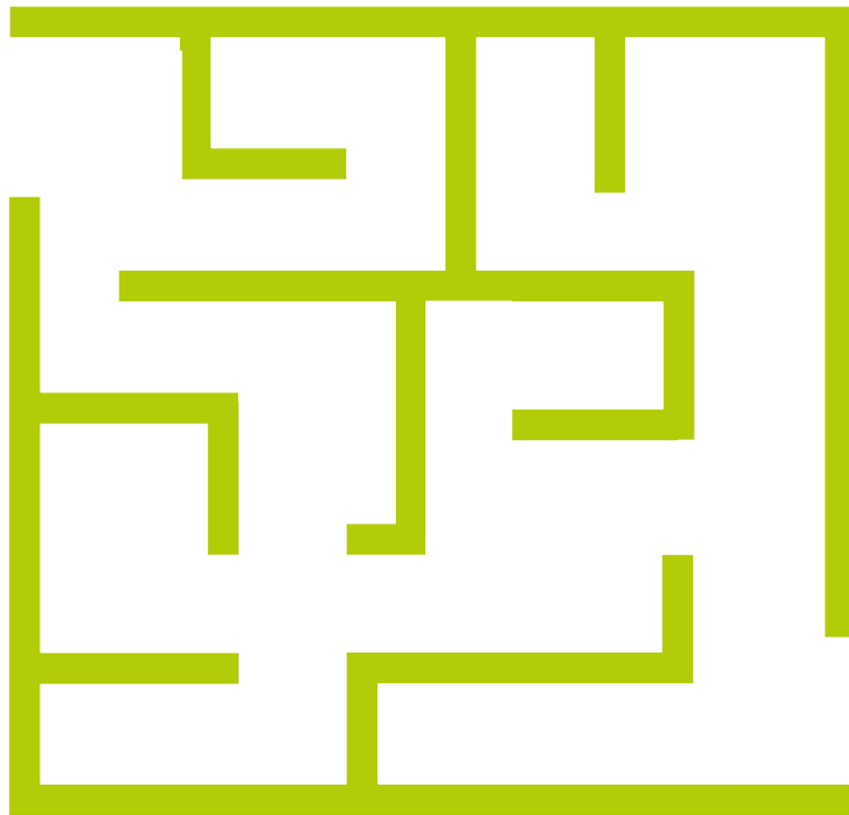
KAPITAŁ LUDZKI
NARODOWA STRATEGIA SPÓJNOŚCIOŚRODEK
ROZWOJU
EDUKACJIUNIA EUROPEJSKA
EUROPEJSKI
FUNDUSZ SPOŁECZNY