

# ZESZYT ĆWICZEŃ Z KARTAMI PRACY DO PROGRAMU EDUKACJI PRZEDSZKOLNEJ

## “Jutro idę do szkoły” ZIMA



**Praca zespołowa pod kierunkiem:**

Bogny Bartosz

**Skład zespołu autorskiego:**

Bogna Bartosz, Liliana Fodrowska,  
Janina Huterska-Górecka, Dorota Rapala

**Współpraca programowo merytoryczna:**

Anna Ł. Adamska

© Copyright by InBIT Szczecin 2013

**Realizatorzy projektu:**

Instytut Organizacji Przedsiębiorstw i Technik Informatycznych  
"InBIT" Sp. z o.o. Oddział w Zgorzelcu  
59-900 Zgorzelec, ul. Daszyńskiego 17  
[www.inbit.pl](http://www.inbit.pl)

Sławomir Anioł FadoS  
[www.fados.pl](http://www.fados.pl)

nakład 1000 egz.  
EGZEMPLARZ BEZPŁATNY

**Opracowanie graficzne, skład i druk:**

"Departament Druku" s.c.  
59-900 Zgorzelec, ul. Łużycka 33b/3

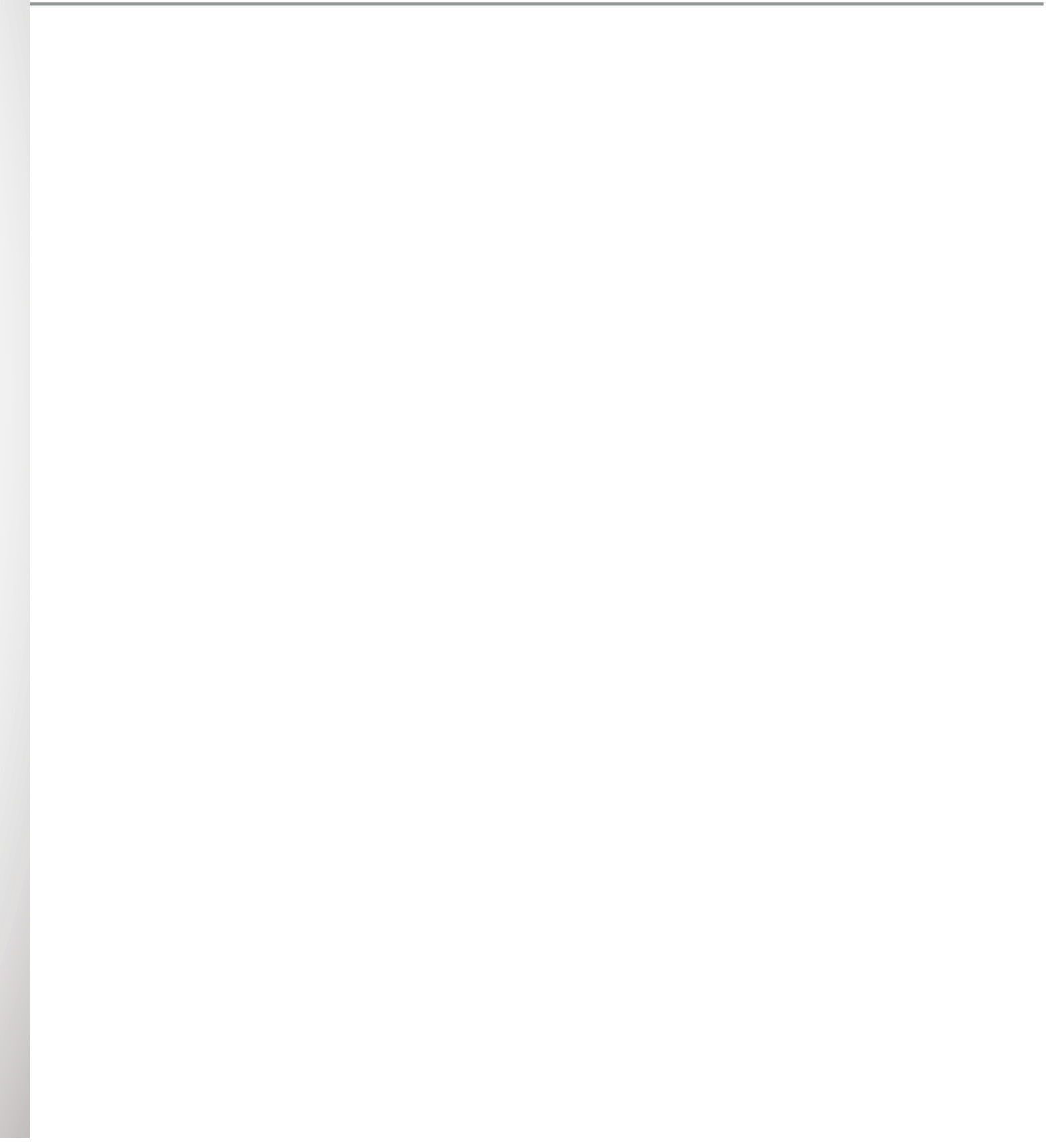
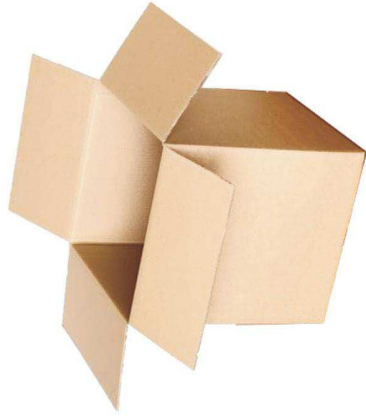

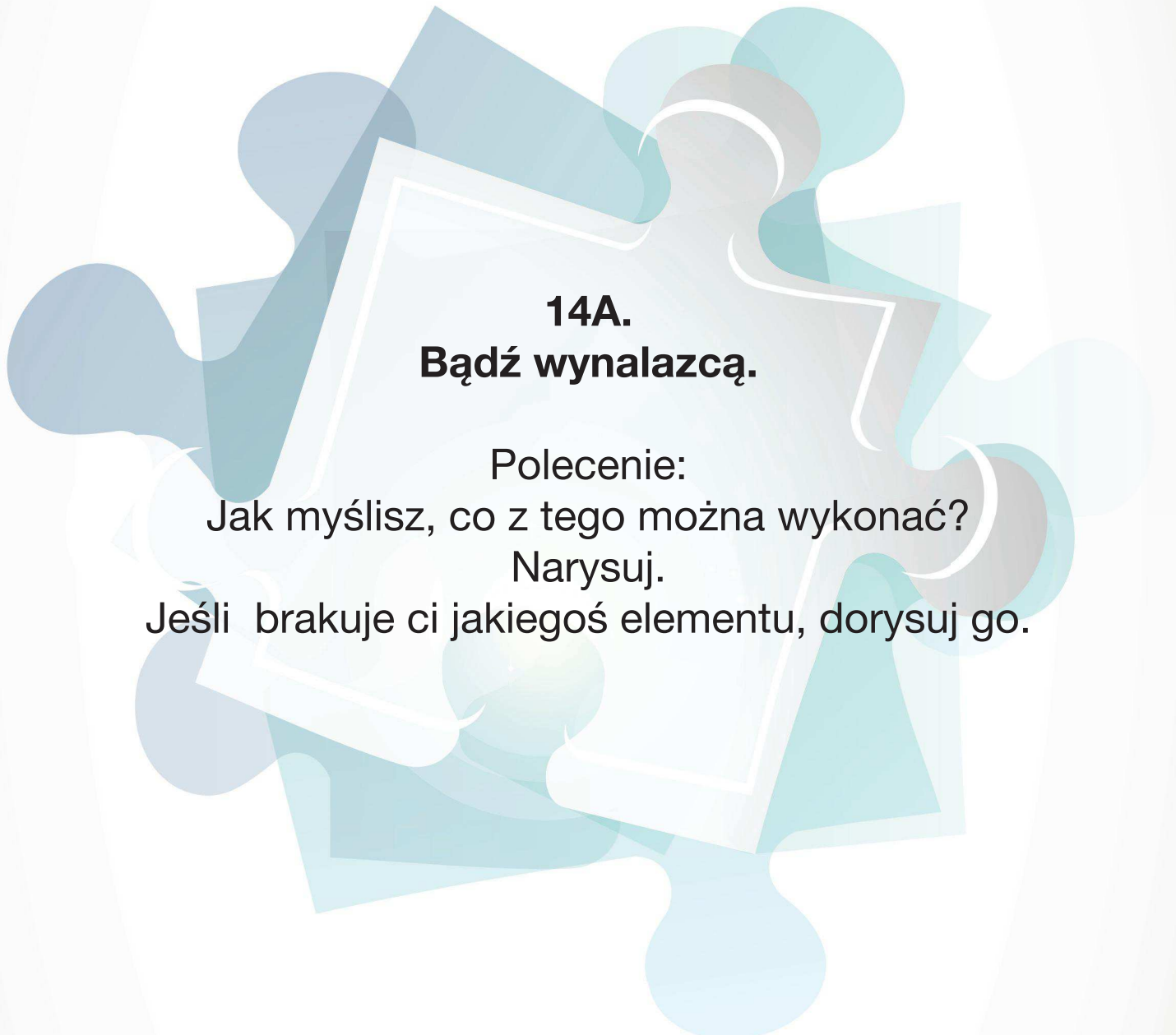

**14A.**  
**Bądź wynalazcą.**

Polecenie:

Jak myślisz, co z tego można wykonać?

Narysuj.

Jeśli brakuje ci jakiegoś elementu, dorysuj go.



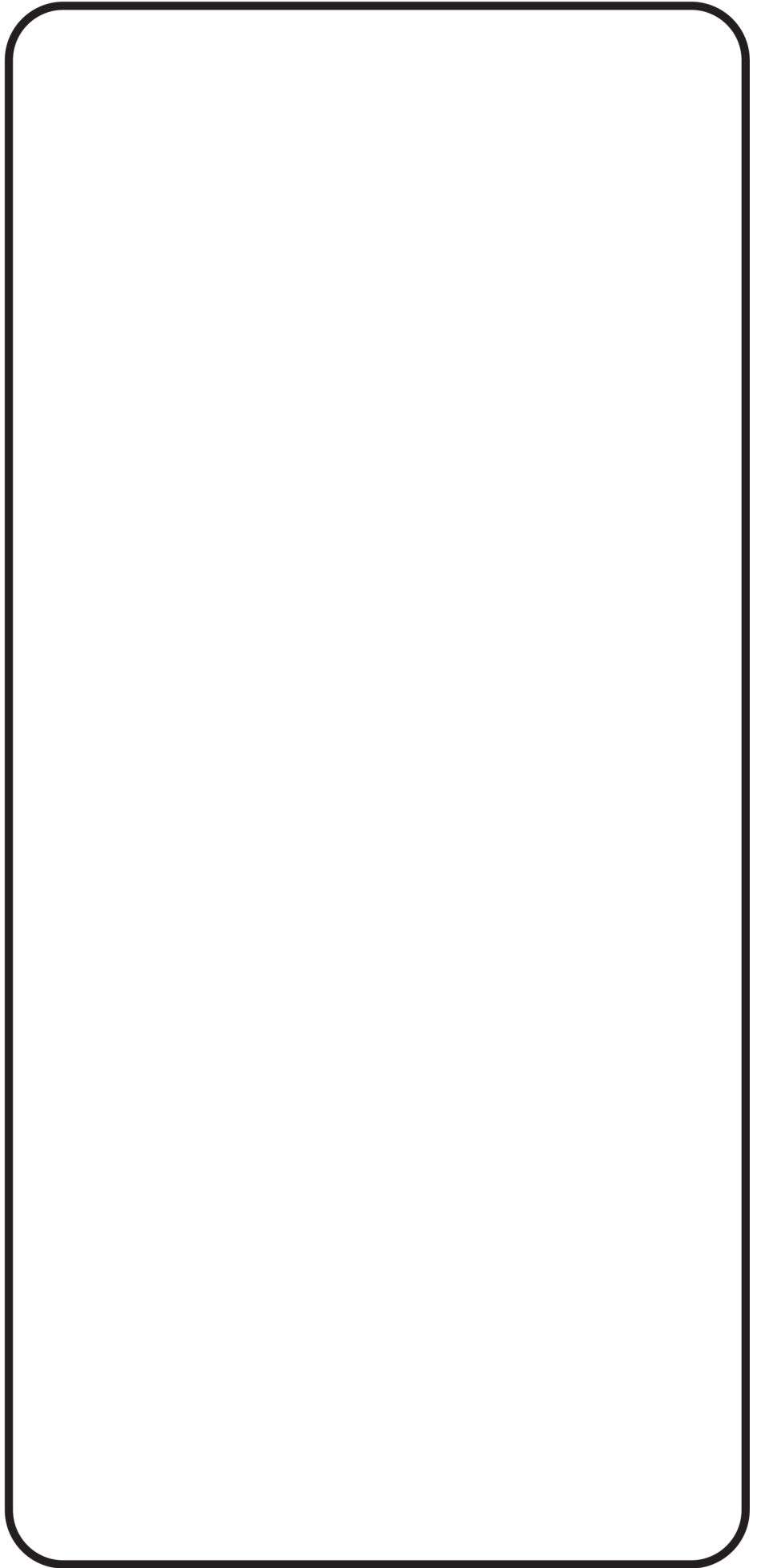
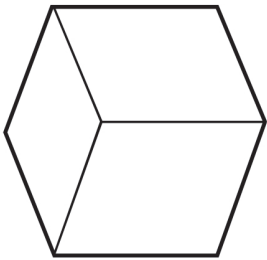
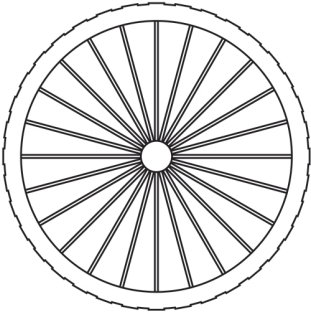

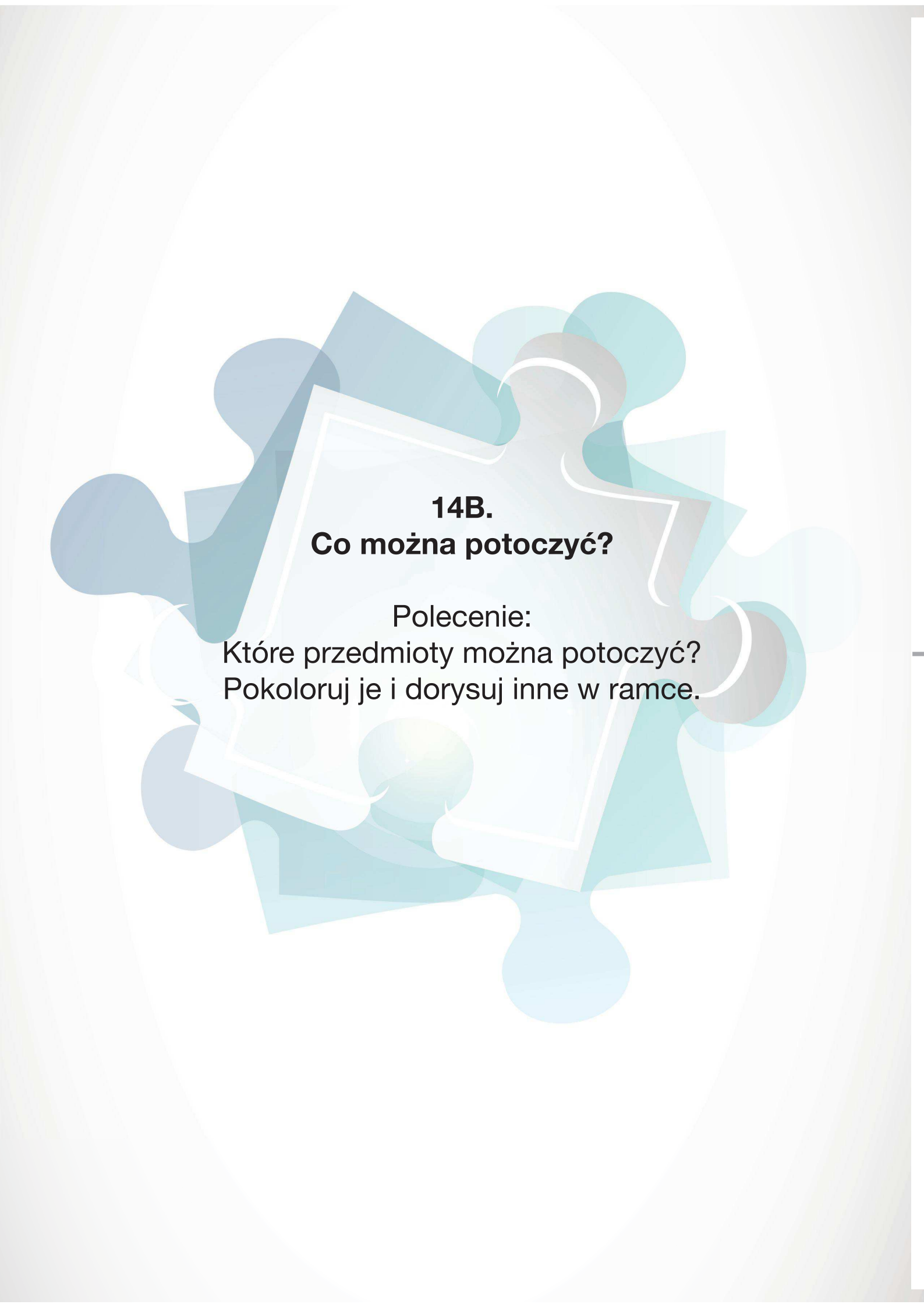

**14B.**  
**Co można potoczyć?**

Polecenie:  
Które przedmioty można potoczyć?  
Pokoloruj je i dorysuj inne w ramce.

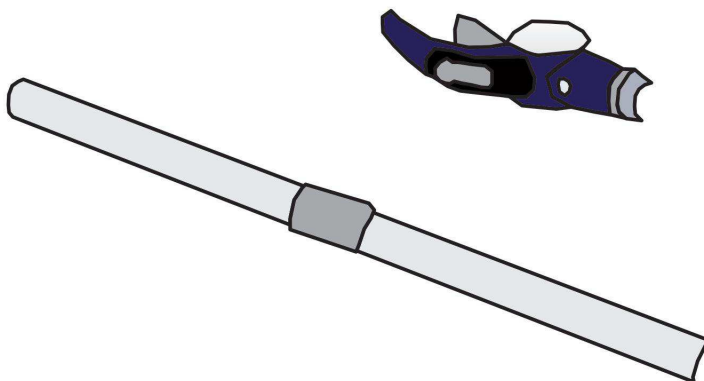
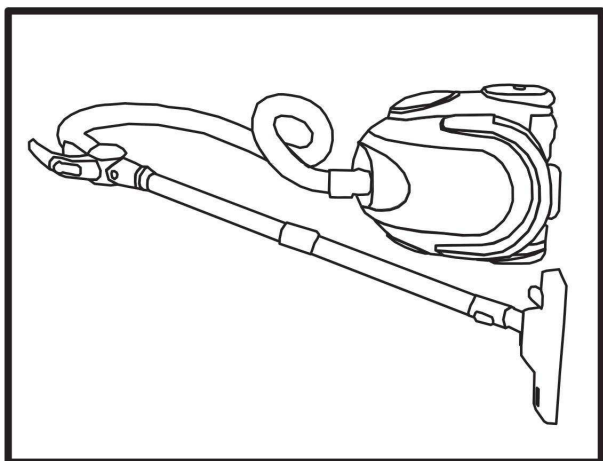
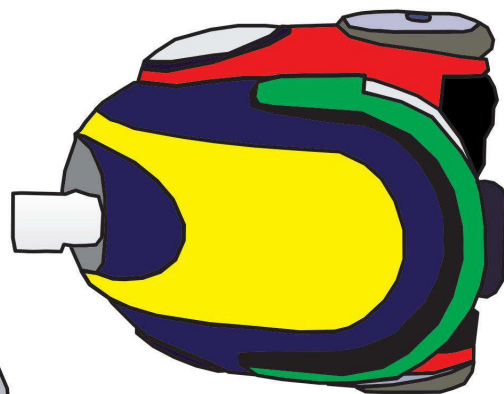
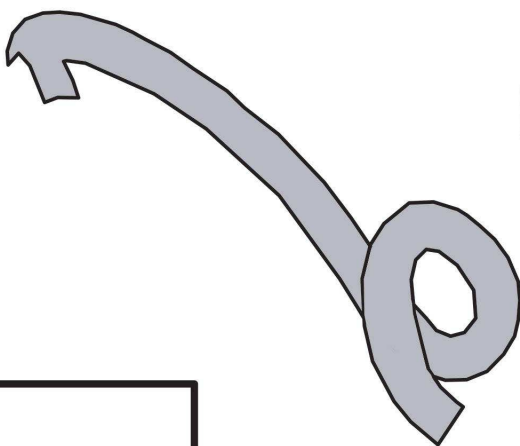
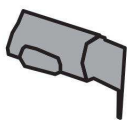
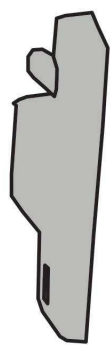
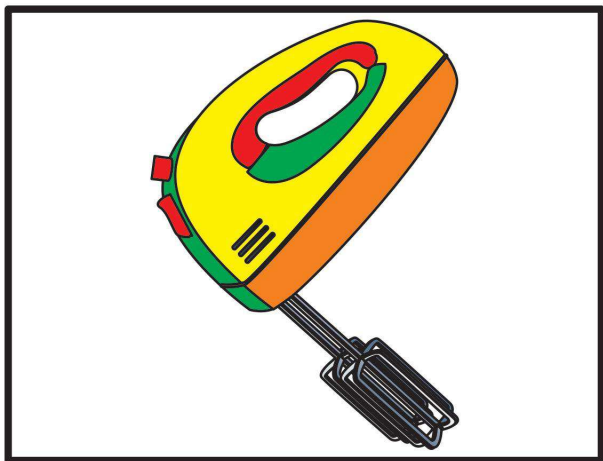
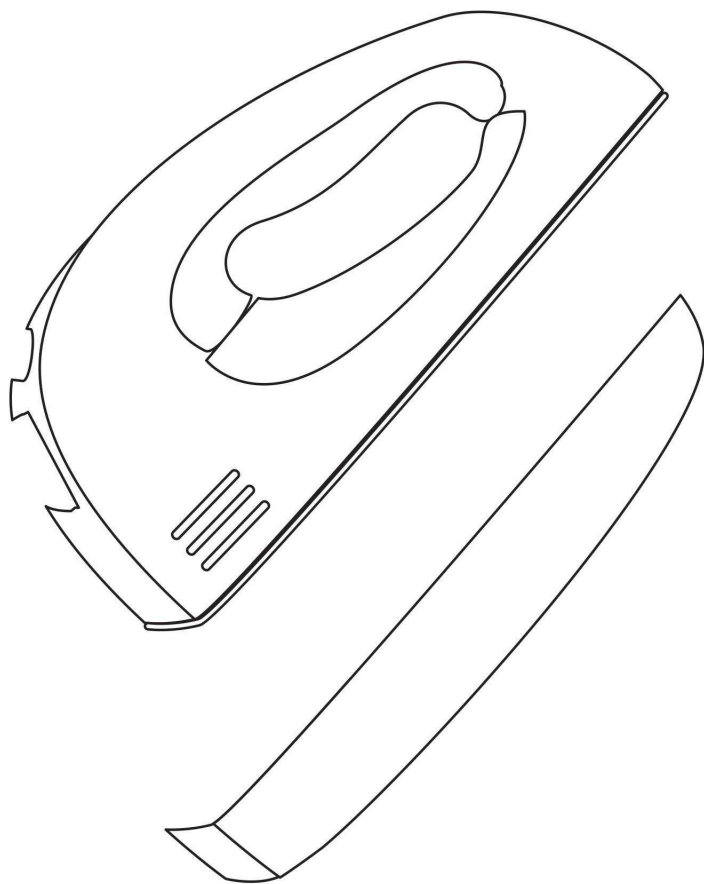
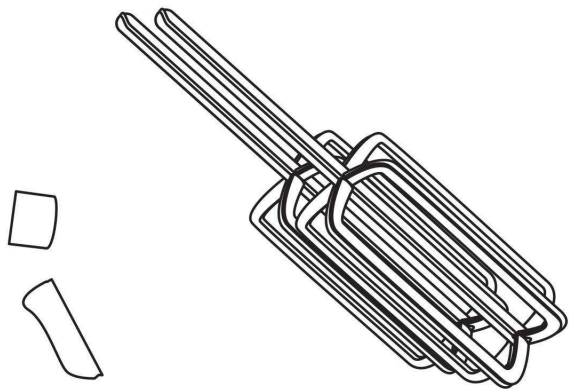



**14C.**  
**Sprzęt gospodarstwa domowego.**

Polecenie:  
Pokoloruj odkurzacz w ramce  
zgodnie ze wzorem.  
Pokoloruj elementy miksera  
zgodnie ze wzorem umieszczonym w ramce.

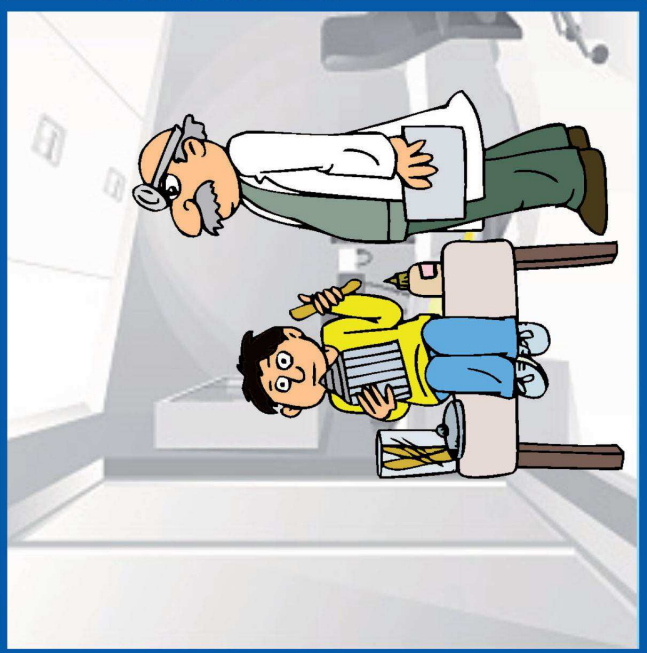
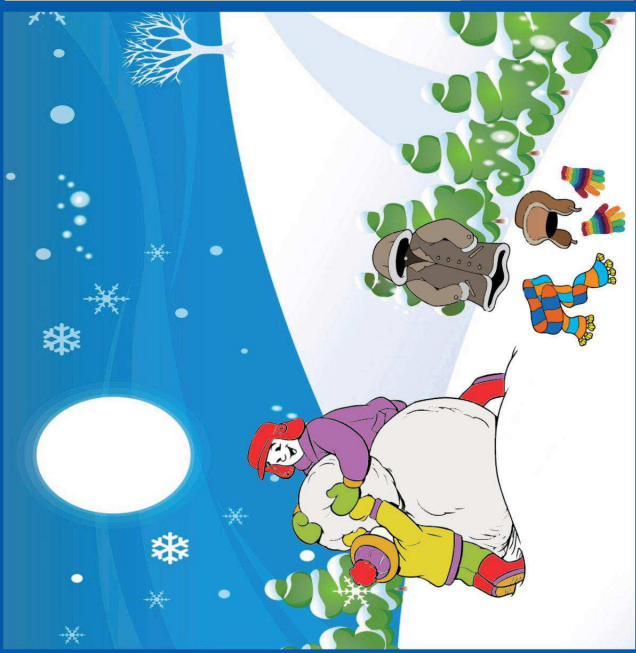
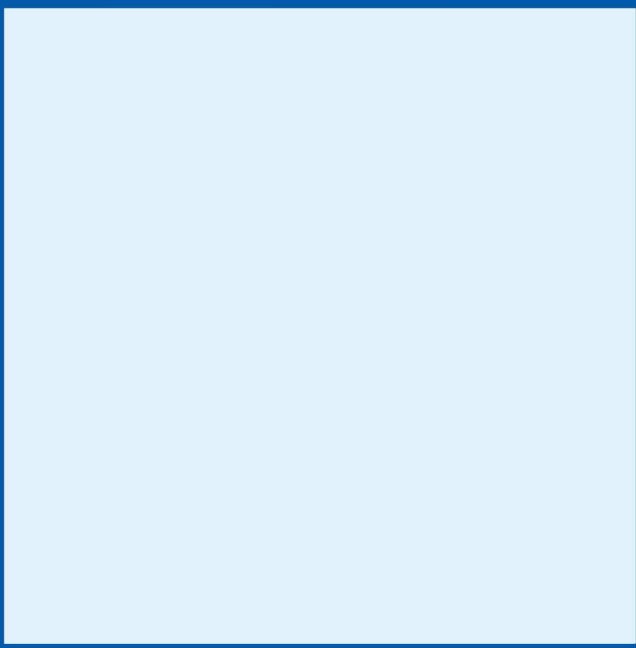



**15A.**  
**Choroba Krzysia.**

Polecenie:  
Wytnij obrazki i ułóż je we właściwej  
kolejności. Opowiedz historię Krzysia.

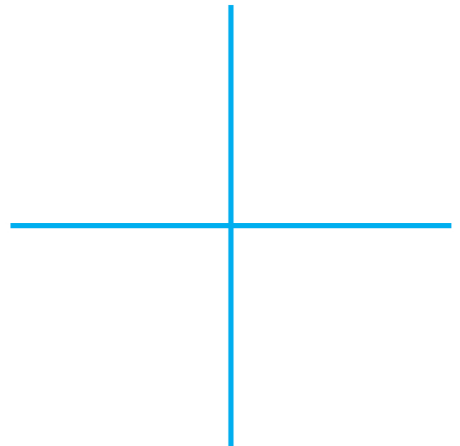
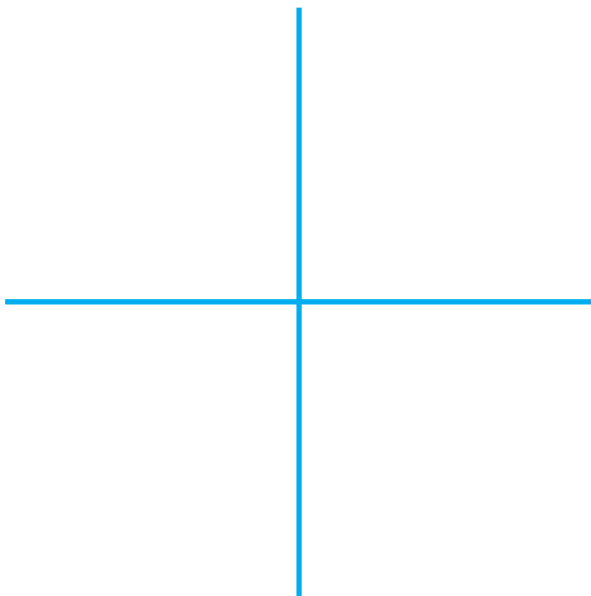
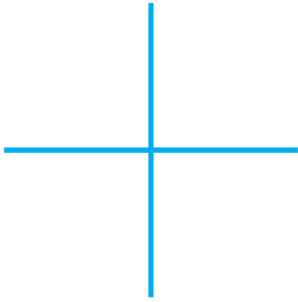
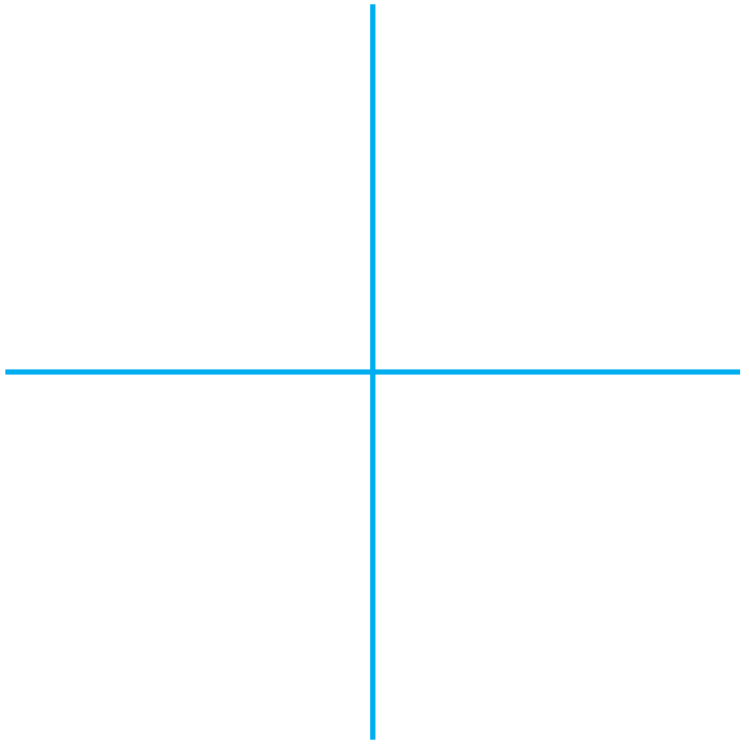



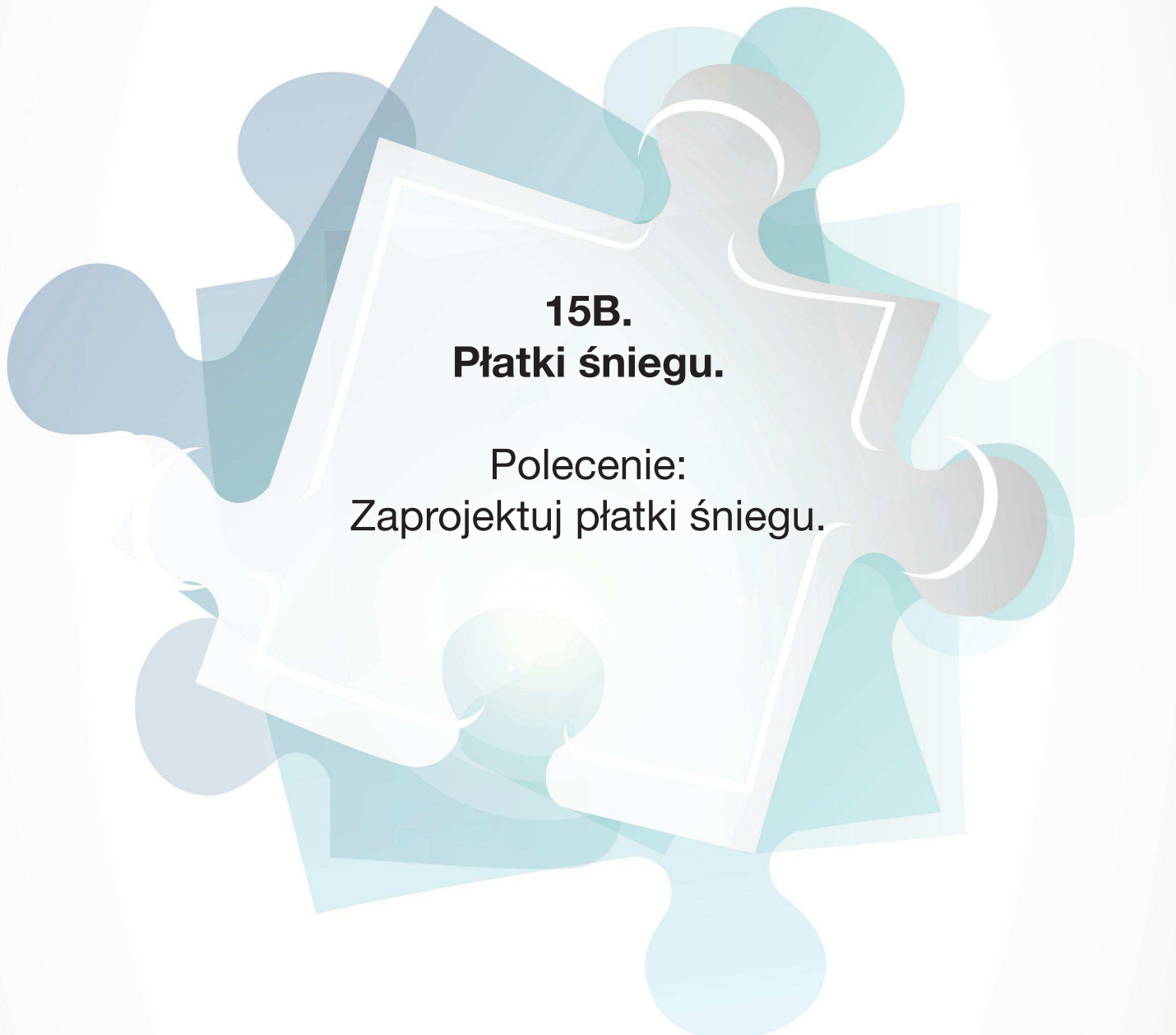

**15B.**  
**Płatki śniegu.**

Polecenie:  
Zaprojektuj płatki śniegu.



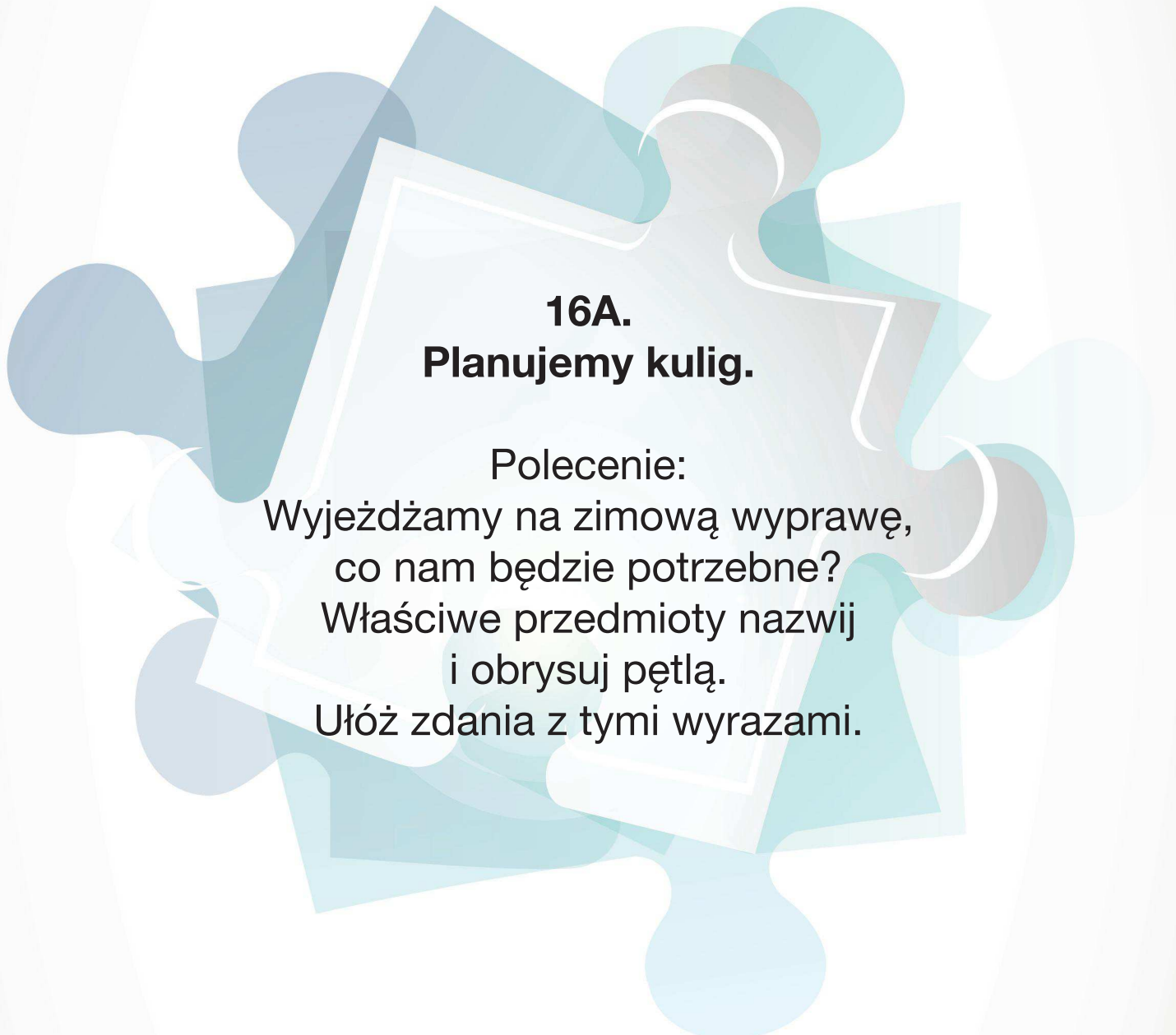

**16A.**  
**Planujemy kulig.**

Polecenie:

Wyjeżdżamy na zimową wyprawę,  
co nam będzie potrzebne?

Właściwe przedmioty nazwij  
i obrysuj pętlą.

Ułóż zdania z tymi wyrazami.

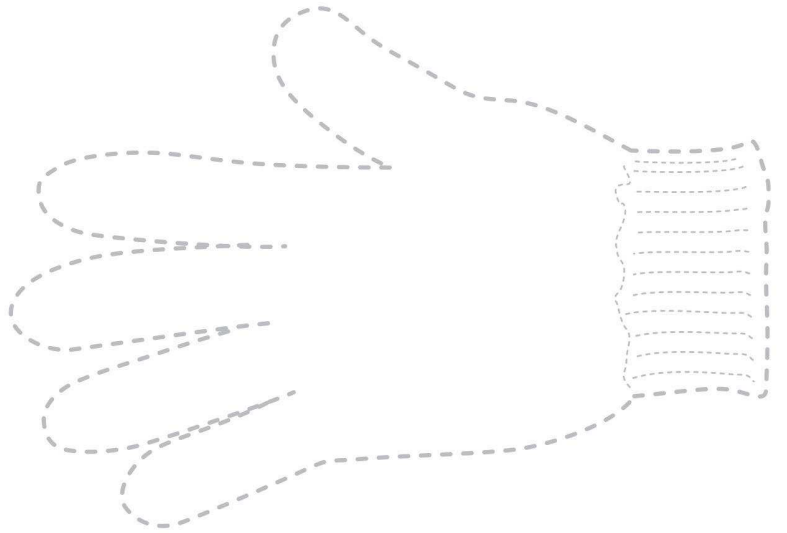
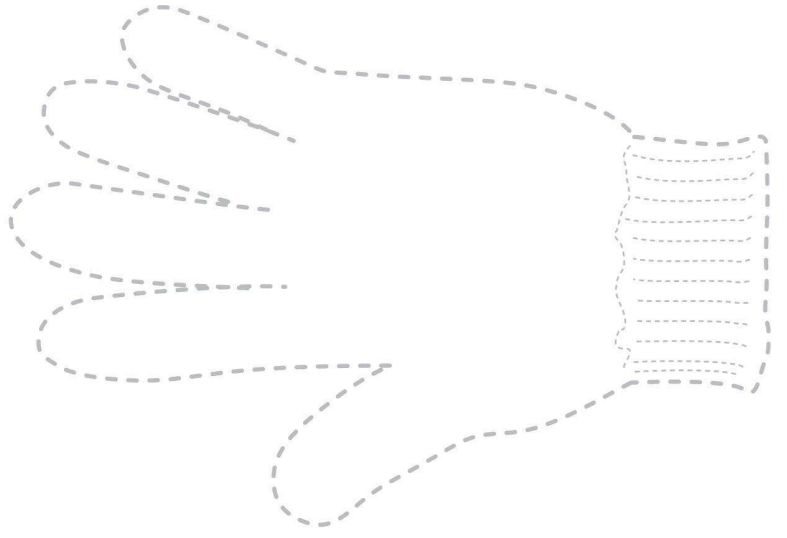





**16B.  
Rękawiczki.**

Polecenie:  
Przelicz rękawiczki.  
Połącz je w pary.  
Powiedz, ile jest par.  
Zaprojektuj swoje rękawiczki.



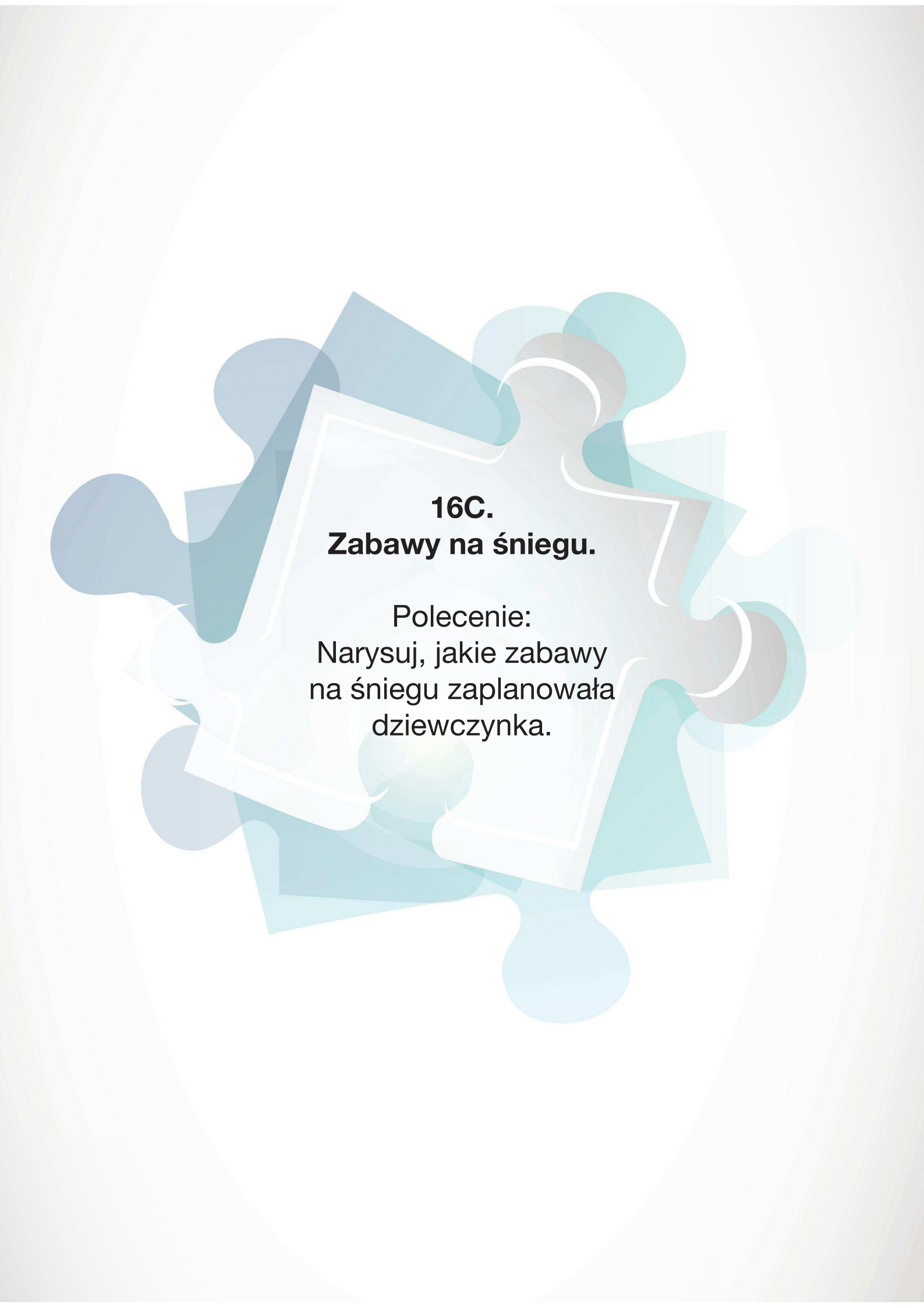

**16C.**  
**Zabawy na śniegu.**

Polecenie:  
Narysuj, jakie zabawy  
na śniegu zaplanowała  
dziewczynka.



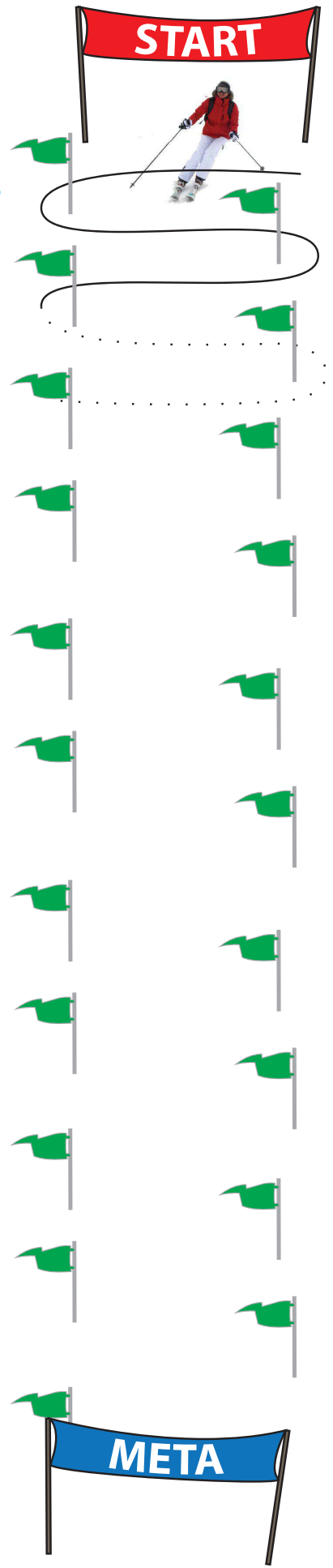
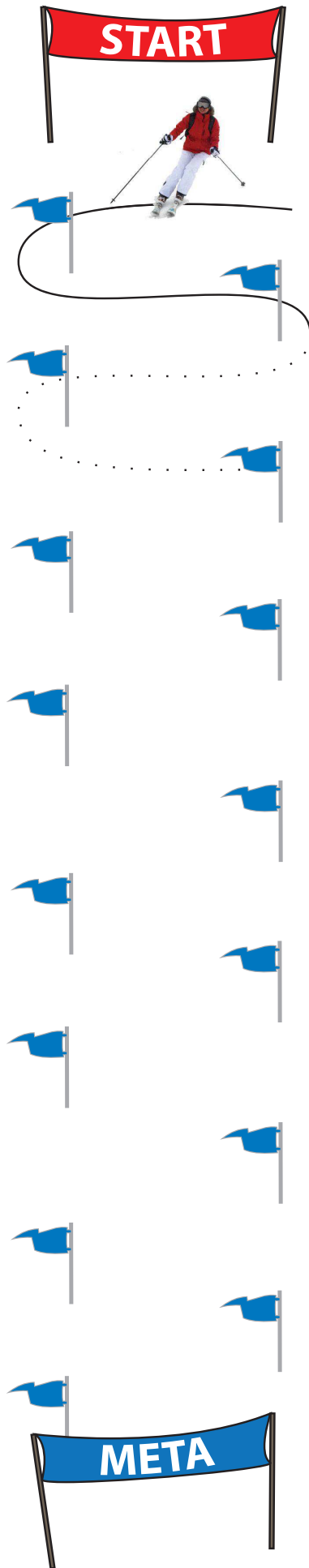
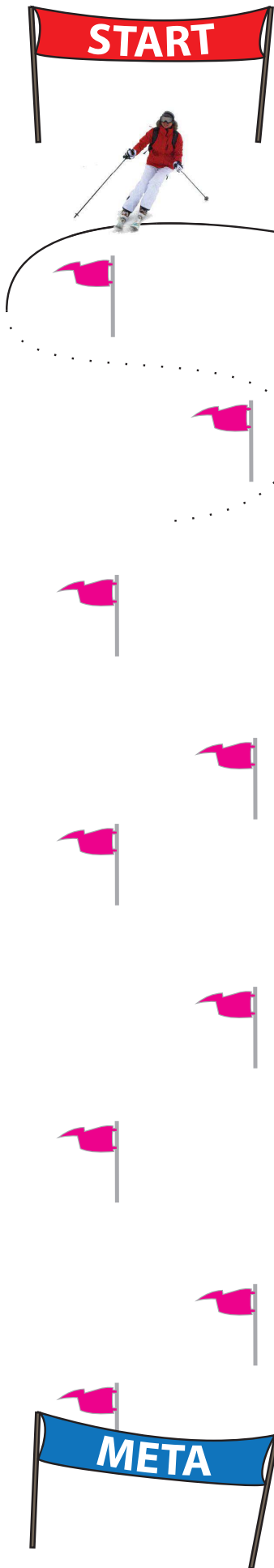



**16D.  
Slalom.**

Polecenie:  
Wyznacz tor przejazdu  
dla każdego narciarza.

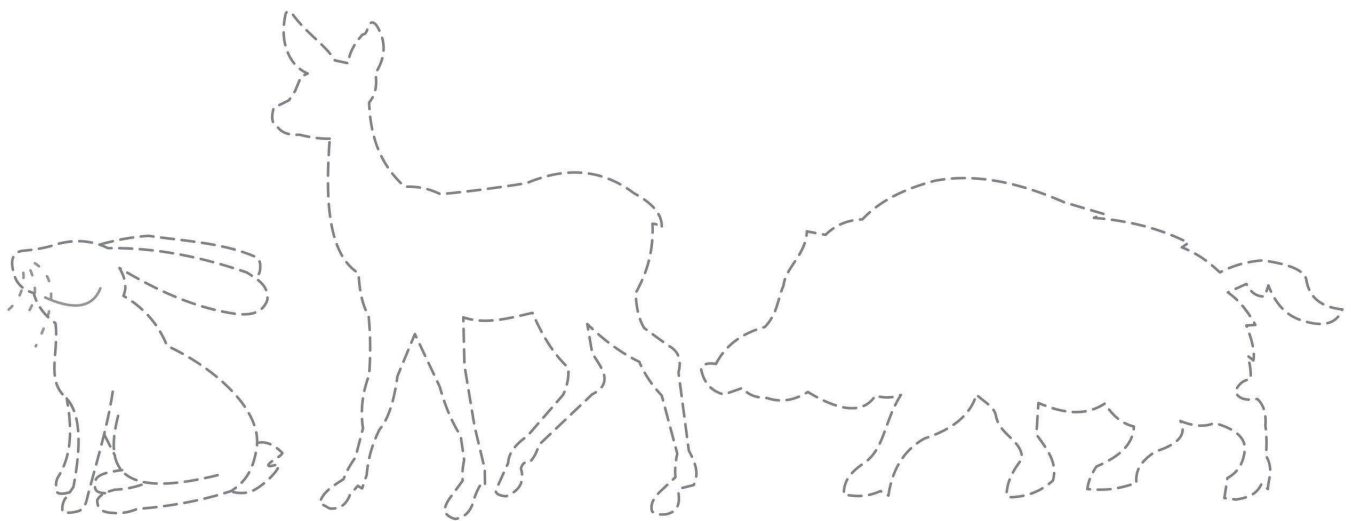

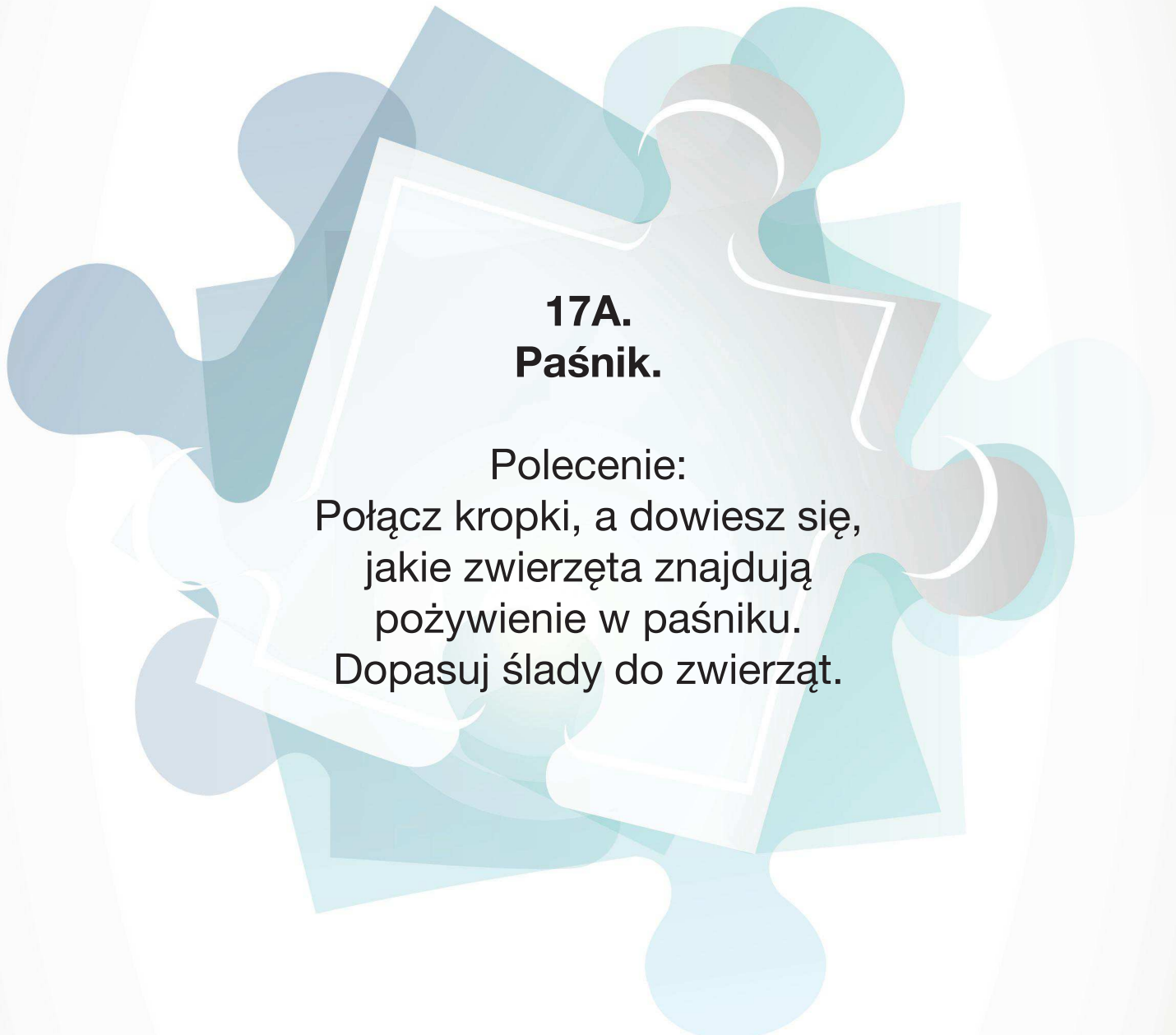

**17A.**  
**Paśnik.**

Polecenie:  
Połącz kropki, a dowiesz się,  
jakie zwierzęta znajdują  
pożywienie w paśniku.  
Dopasuj ślady do zwierząt.

w w w w w w w w w w

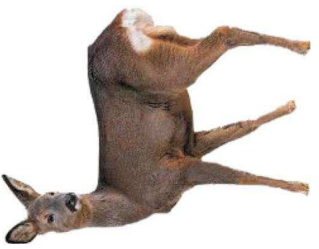



**17B.**  
**Dokarmiamy ptaki.**

Polecenie:  
Poprowadź kolorową strzałką  
do karmnika,  
te osobniki, które dokarmiamy w karmniku.  
Otocz pętlą te zwierzęta,  
w których nazwie słychać głoskę “i”.



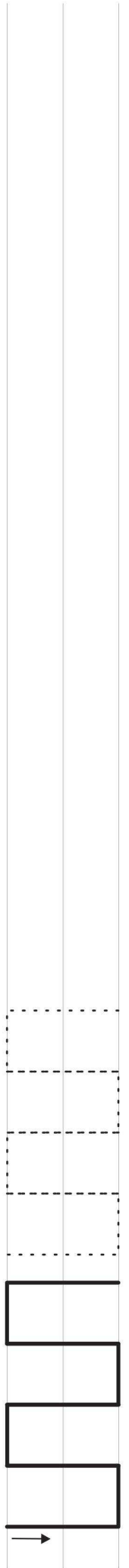
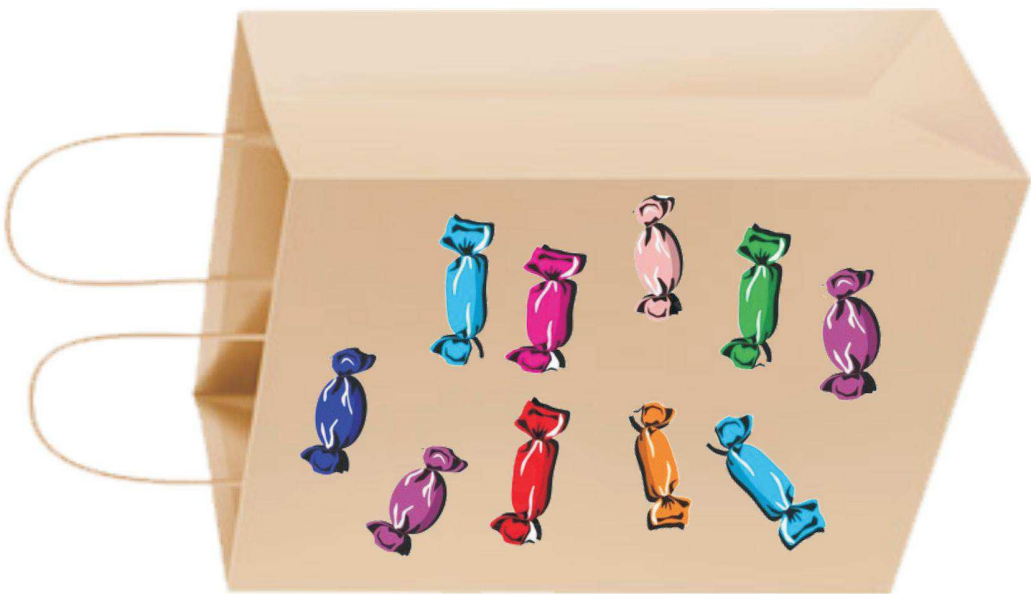
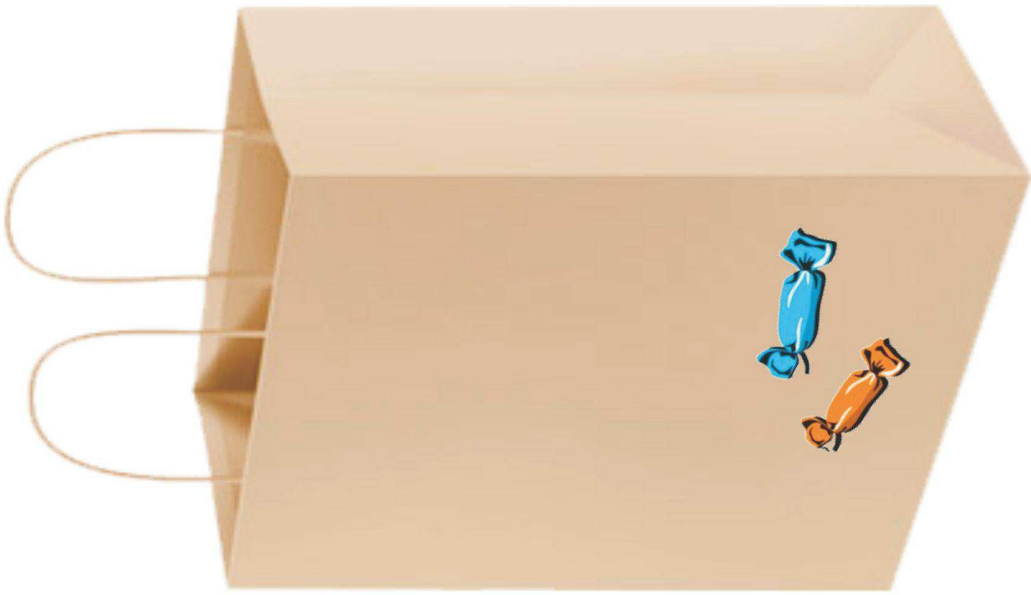



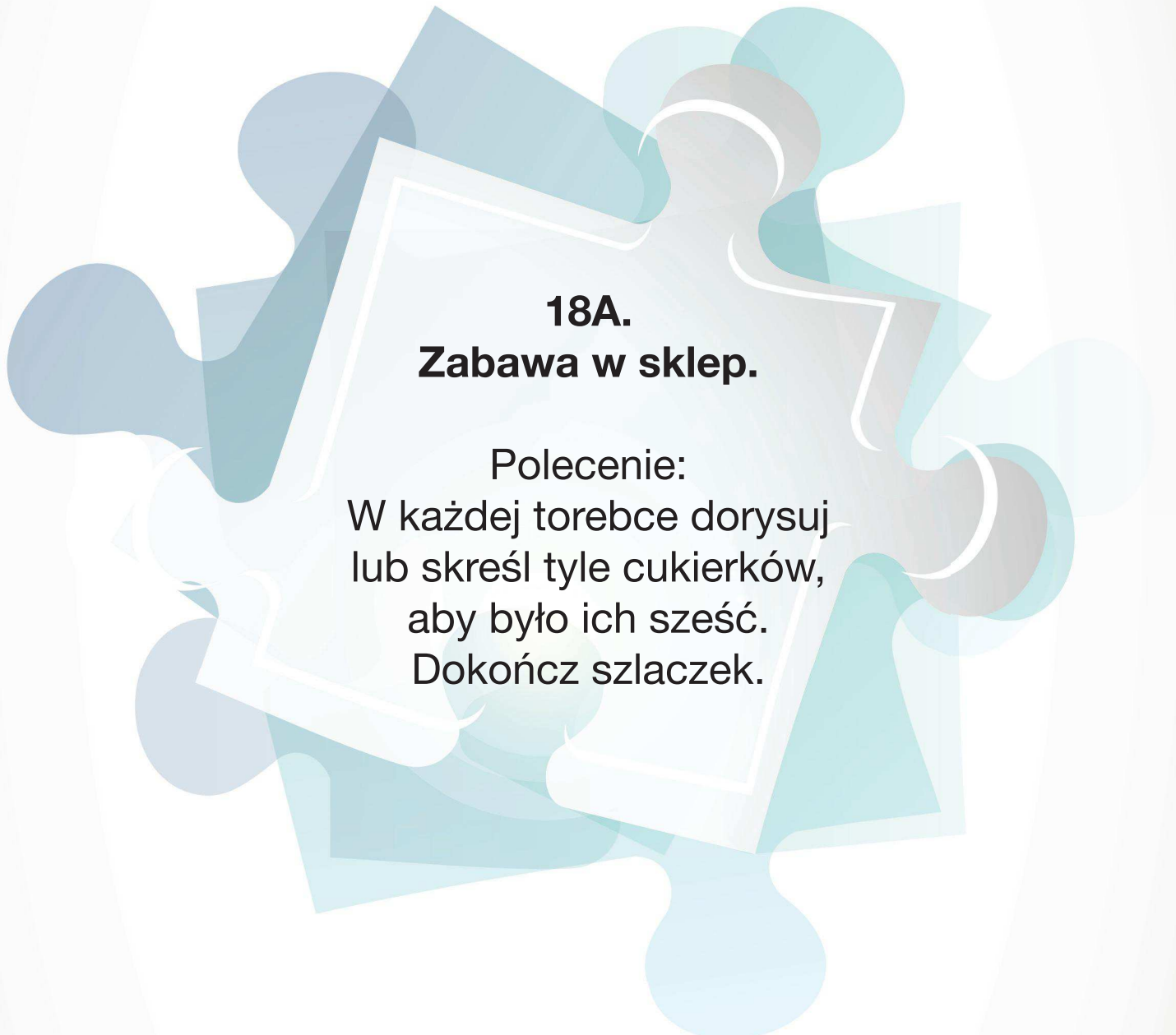

**18A.**  
**Zabawa w sklep.**

Polecenie:  
W każdej torebce dorysuj  
lub skreśl tyle cukierków,  
aby było ich sześć.  
Dokończ szlaczek.

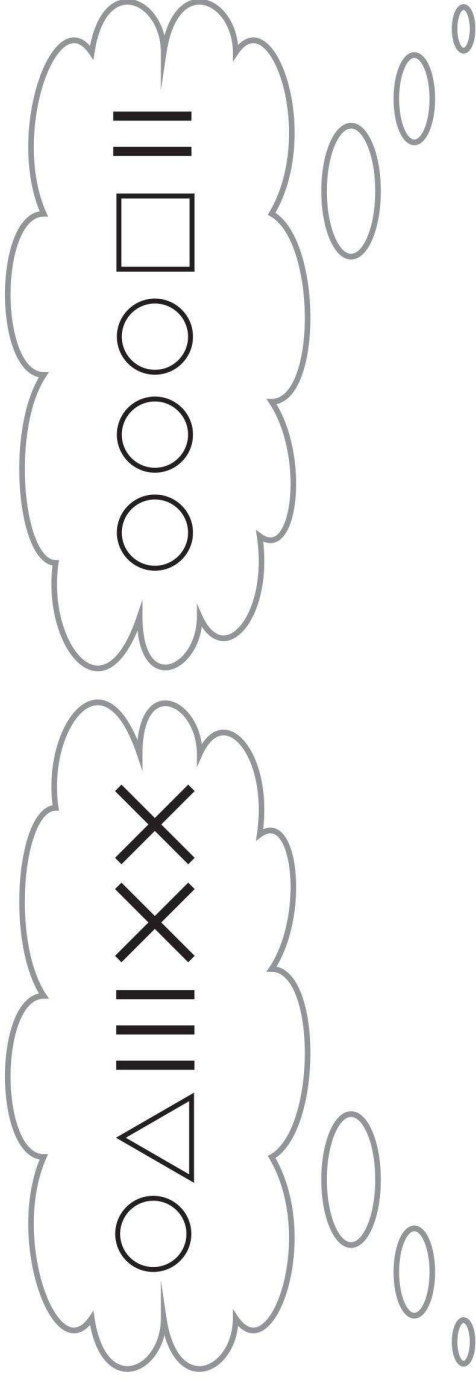
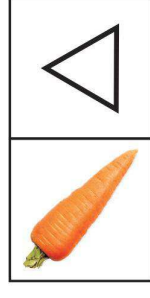
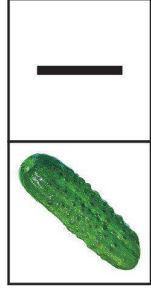
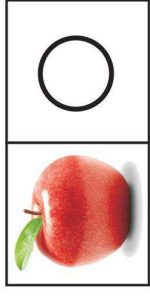
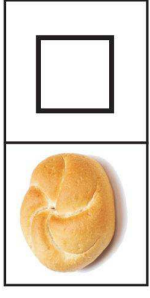

Ewa



Adam

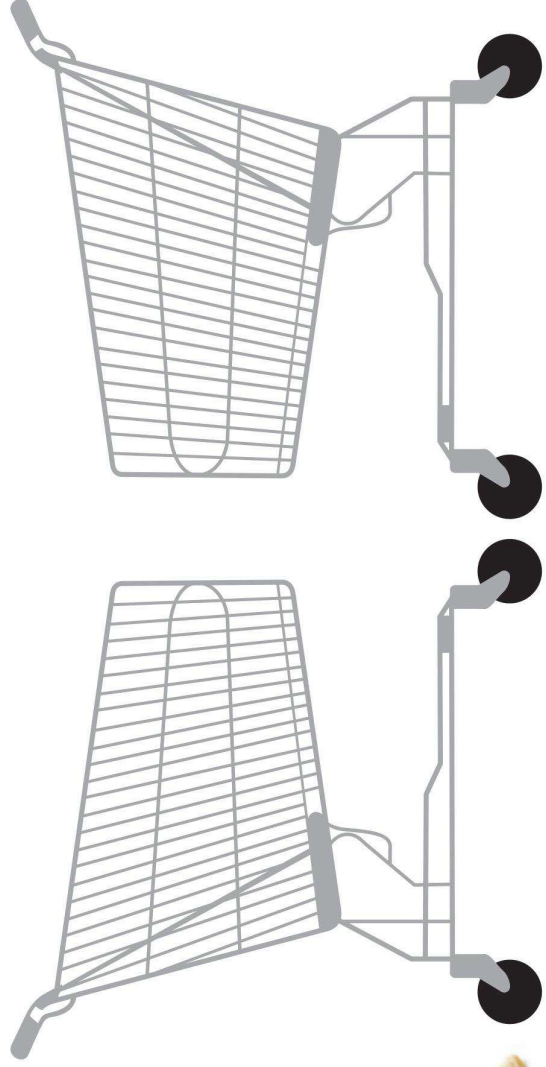

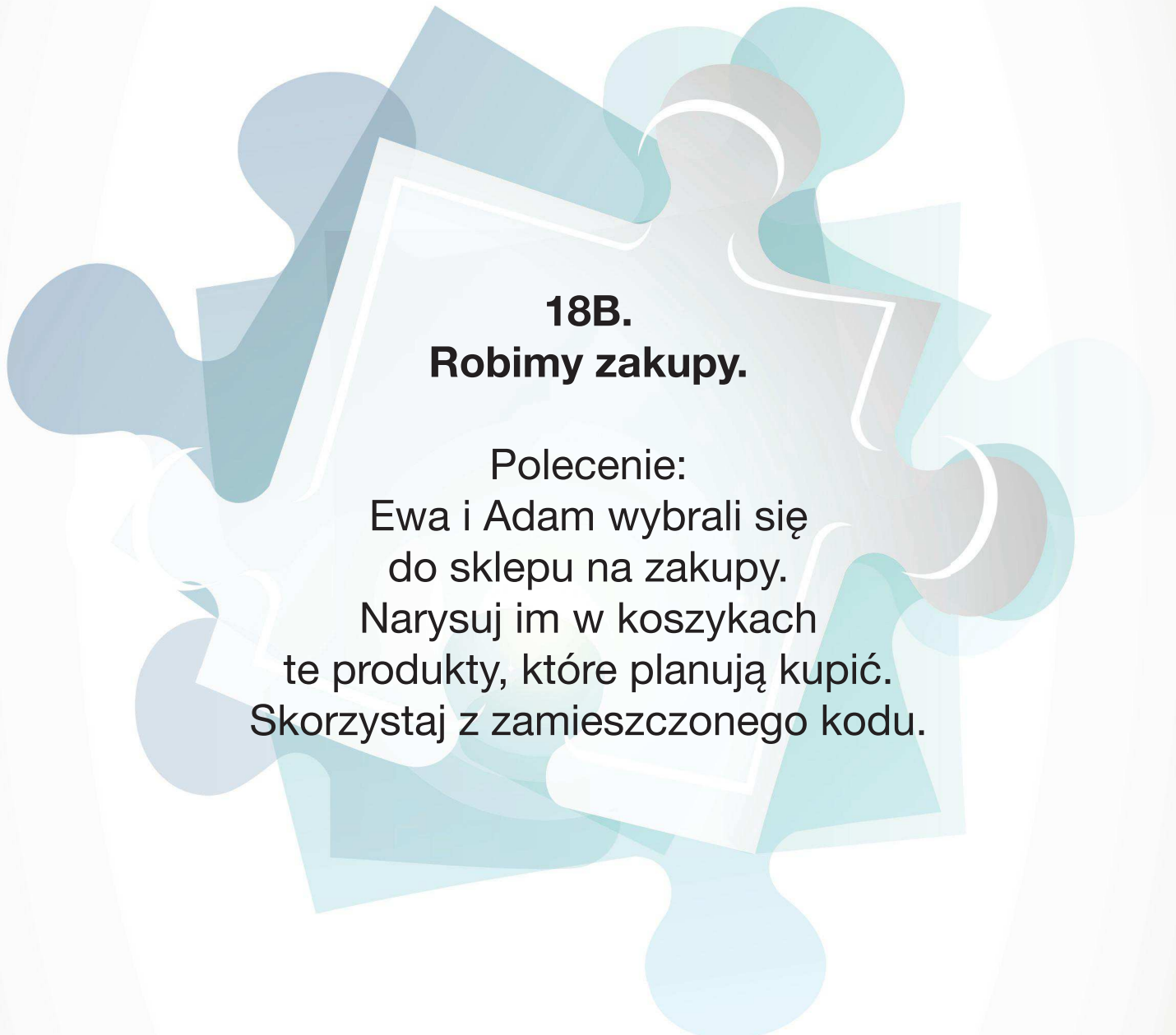

**18B.**  
**Robimy zakupy.**

Polecenie:  
Ewa i Adam wybrali się  
do sklepu na zakupy.  
Narysuj im w koszykach  
te produkty, które planują kupić.  
Skorzystaj z zamieszczonego kodu.

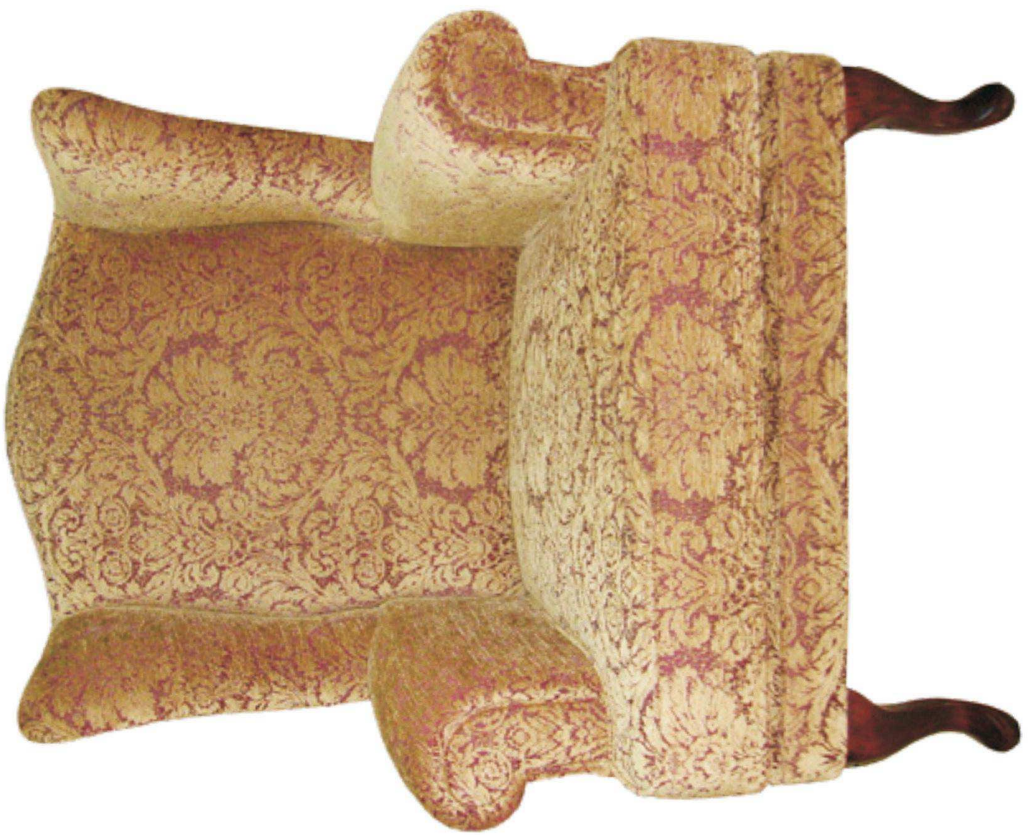



**19A.  
Fotel.**

Polecenie:

Wyobraź sobie, że siedzisz na fotelu.

Po prawej stronie fotela stoi lampa.

Po lewej stronie fotela jest stolik,  
a na nim leży książka.

Przed fotelem siedzi kot i patrzy  
na kłębek, który wpadł mu pod fotel.

Narysuj to.



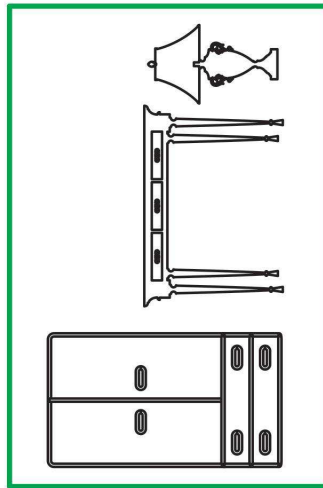
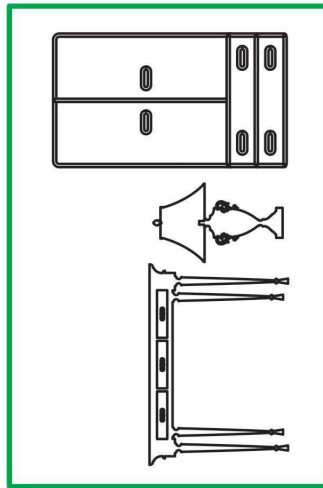
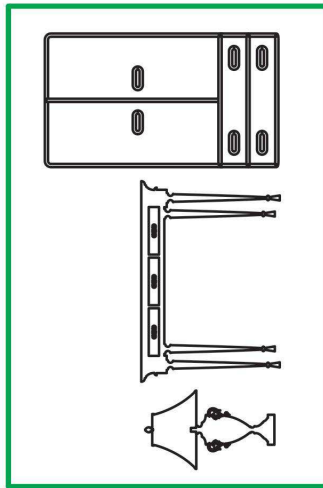
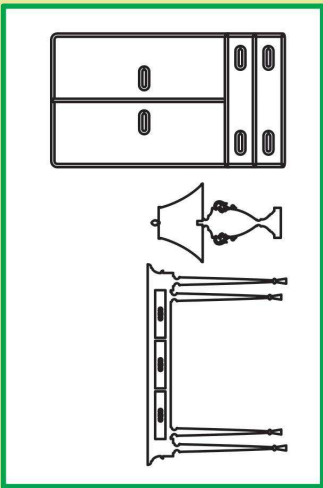
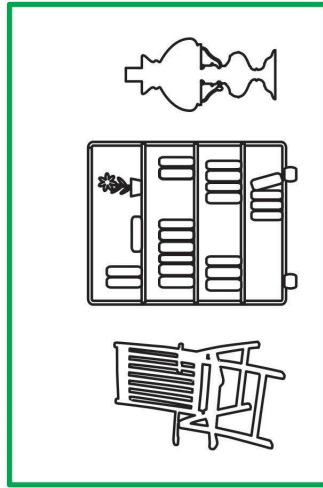
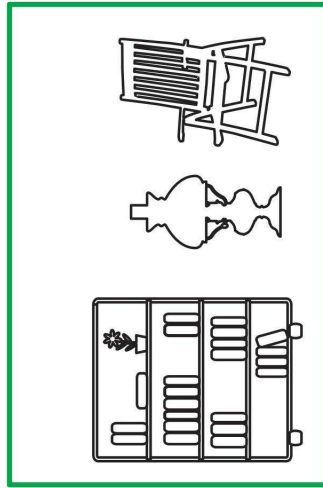
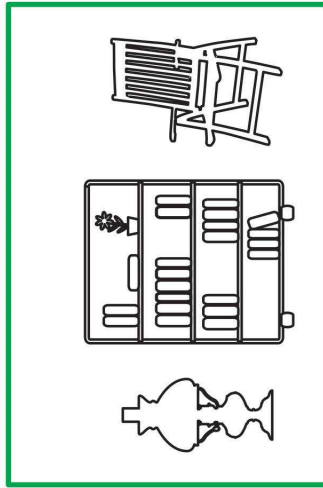
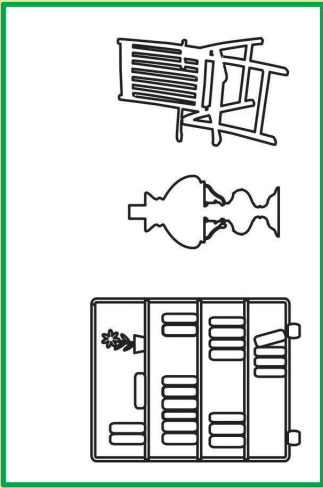
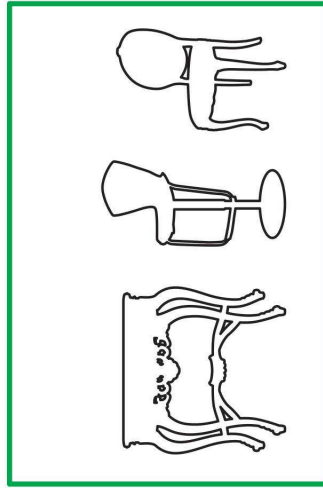
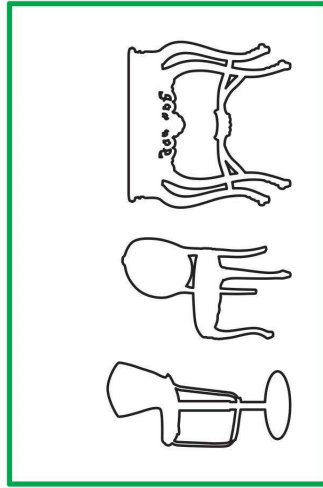
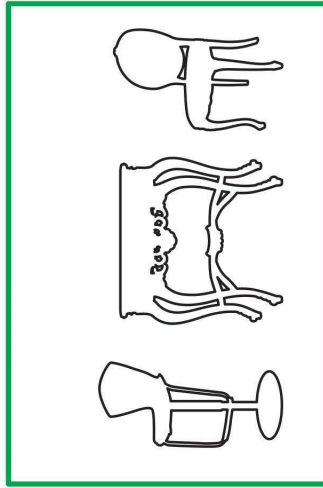
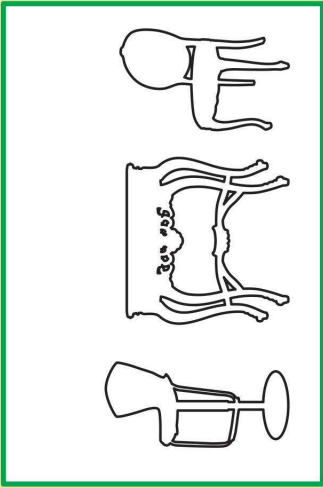
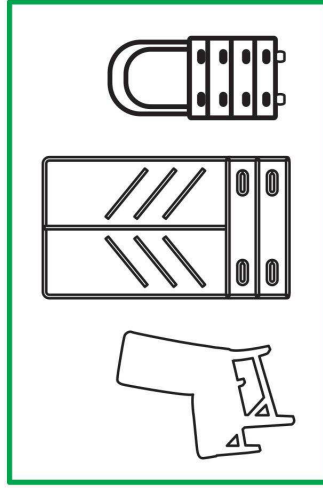
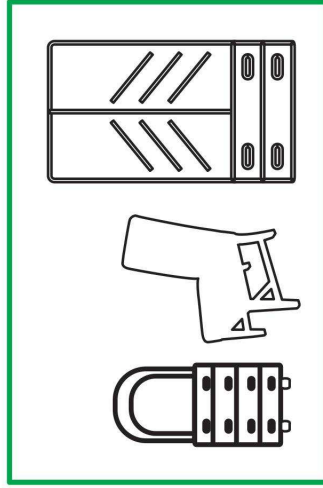
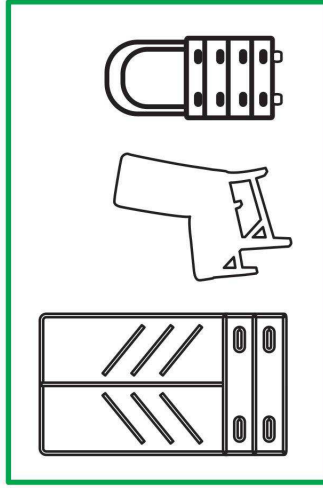
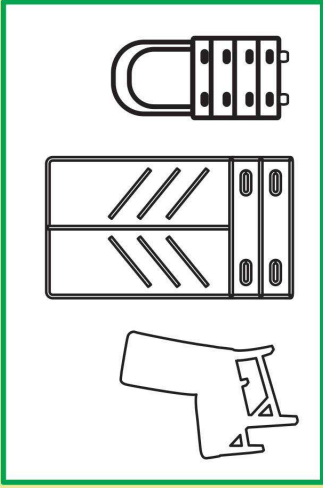



**19B.**  
**Ustawienie mebli.**

Polecenie:  
Pokoloruj tylko te obrazki,  
które są identyczne jak we wzorze.



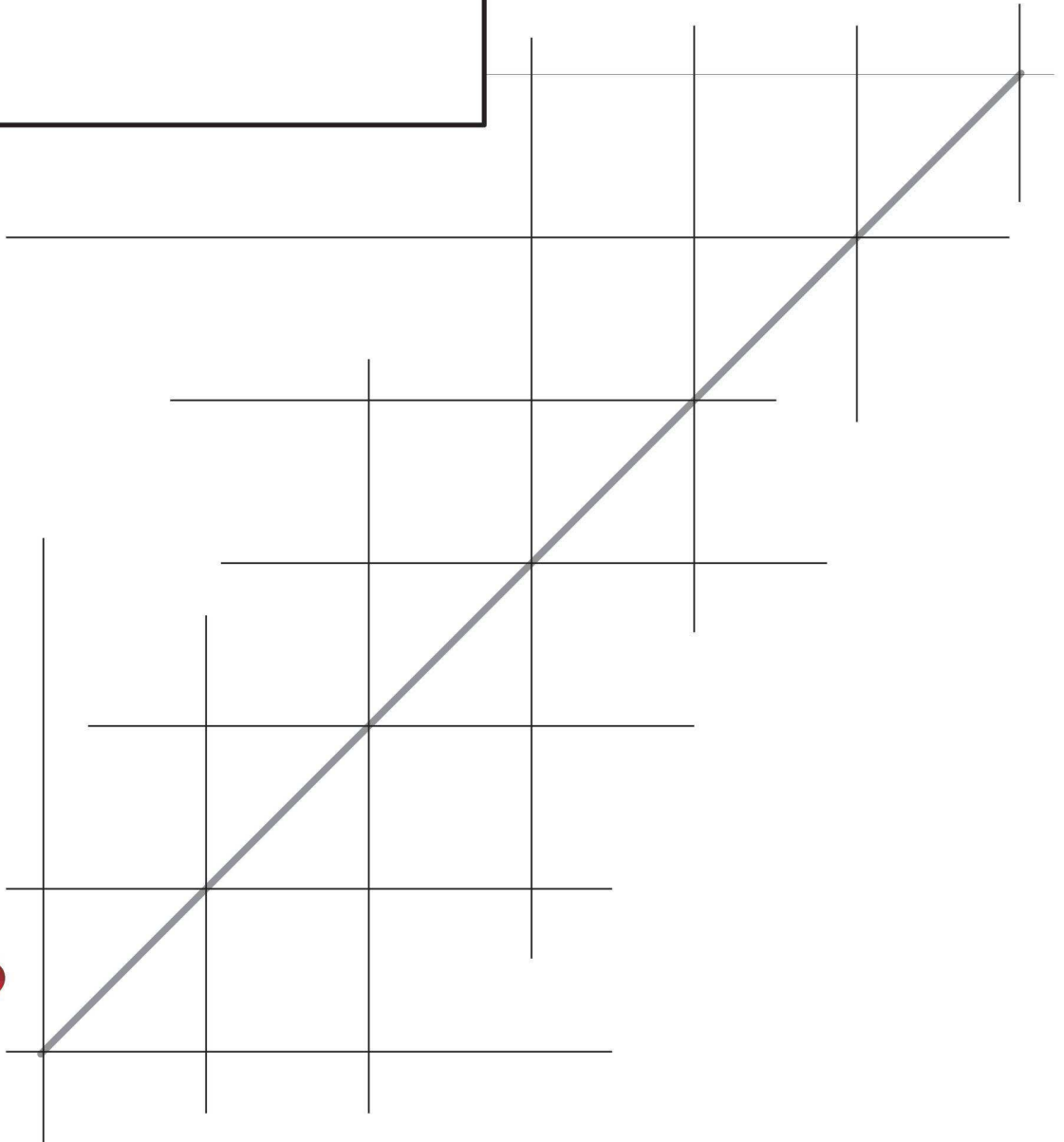



**19C.  
Prezent.**

Polecenie:

Doprowadź Mikołaja do prezentu  
po ukrytych na rysunku schodach.

Zaznacz schody zieloną kredką,  
a w okienku narysuj wymarzony prezent.

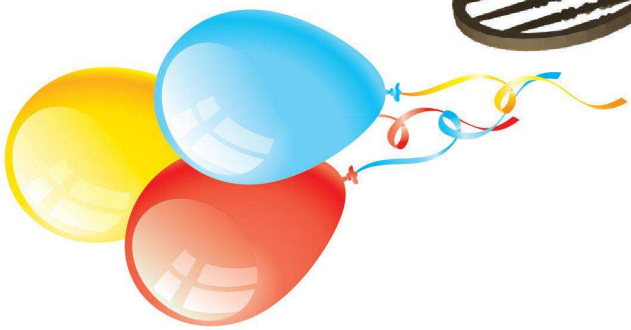
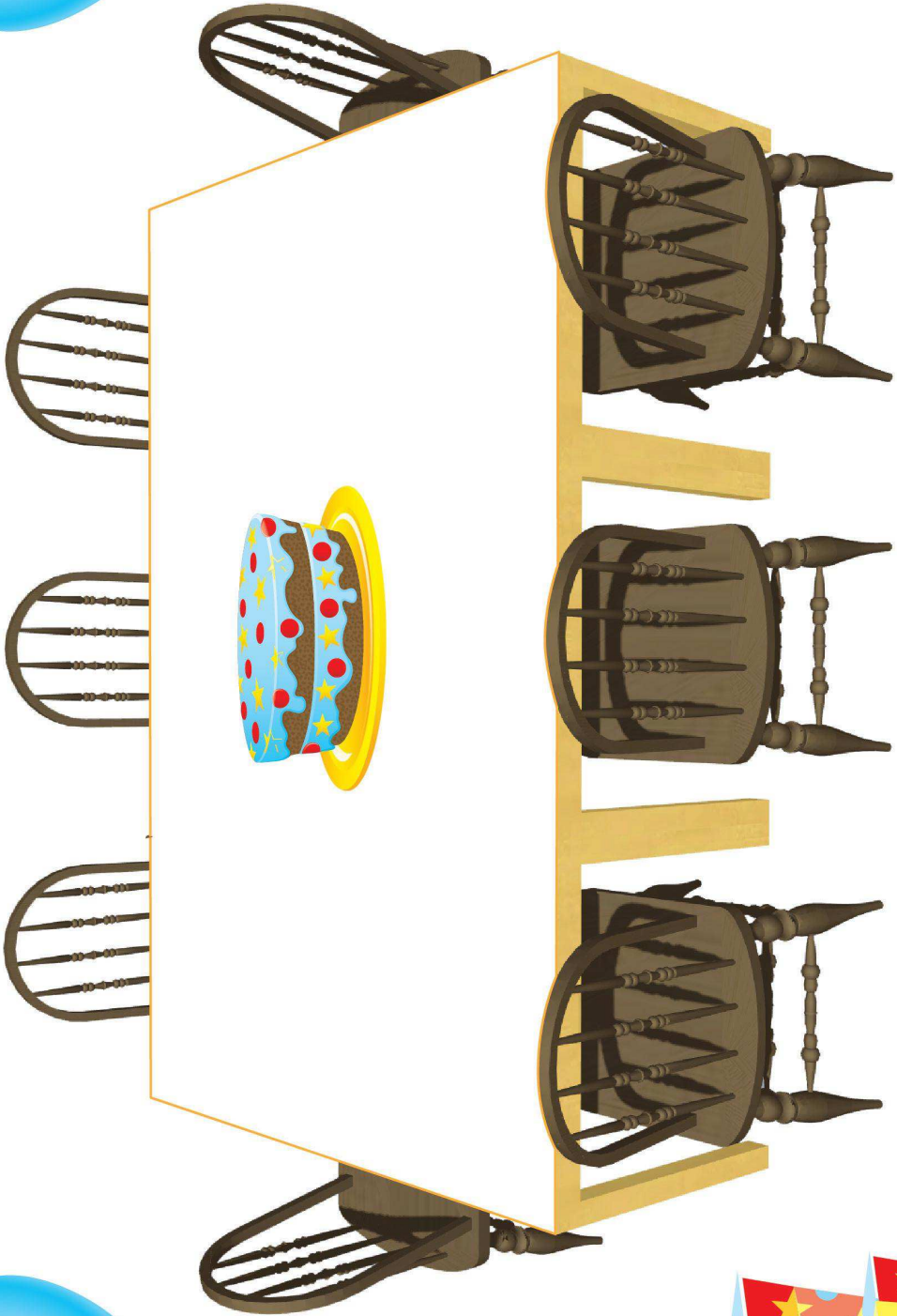
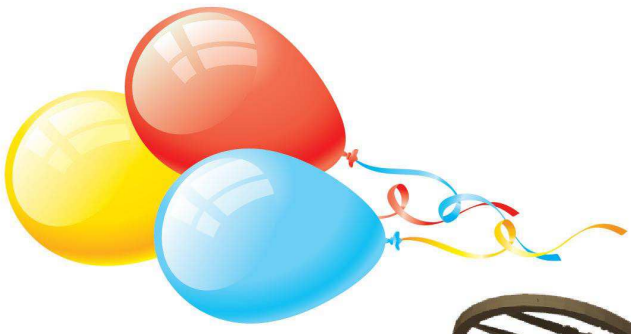



**20A.**  
**Urodziny.**

Polecenie:

Dziś są twoje urodziny.

Przyklej na torcie tyle świeczek, ile masz lat.

Zaproszonych gości jest o jeden  
więcej niż świeczek na torcie.

Narysuj tyle talerzyków na stole,  
ile osób będzie na urodzinach.

Nie zapomnij o sobie.

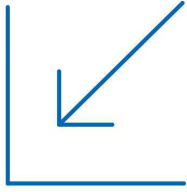
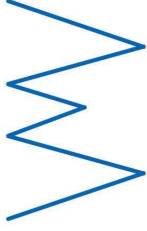
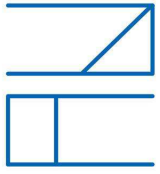
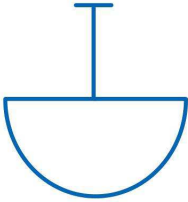
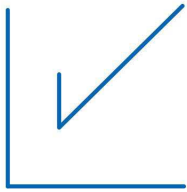
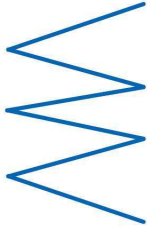
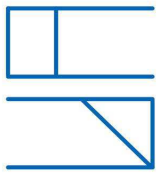
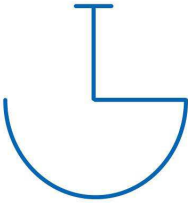
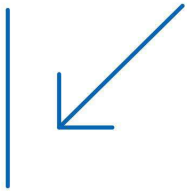
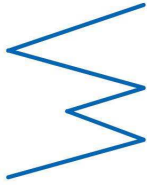
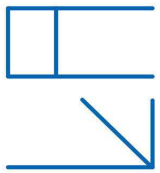
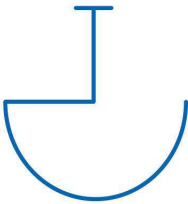
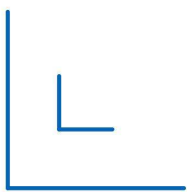
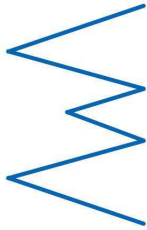
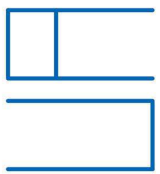
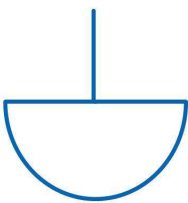
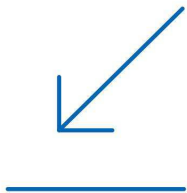
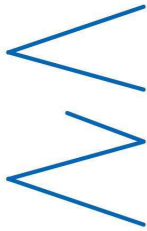
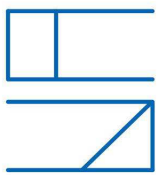
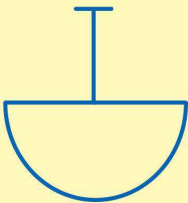
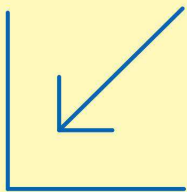
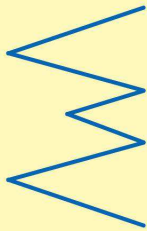
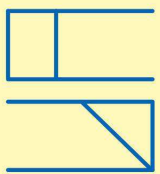





			
			
			
			
			
			



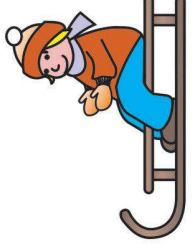

**20B.**  
**Identyczny obrazek.**

Polecenie:  
Przyjrzyj się uważnie rysunkom w szeregu.  
Zaznacz tylko ten, który jest identyczny.

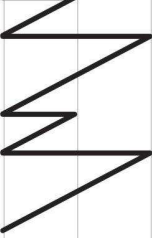
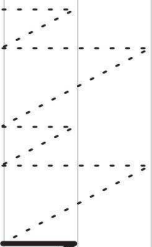

					
Myszę, że ...					
Wiem, że ...					



**21A.**  
**Pagórkowy zjazd.**



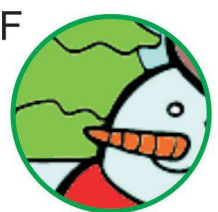
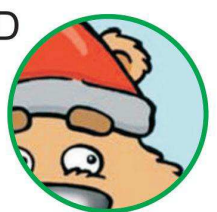
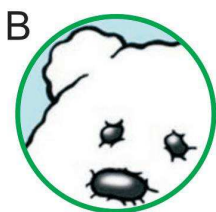
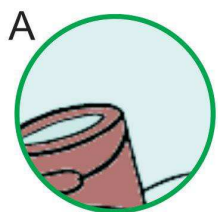

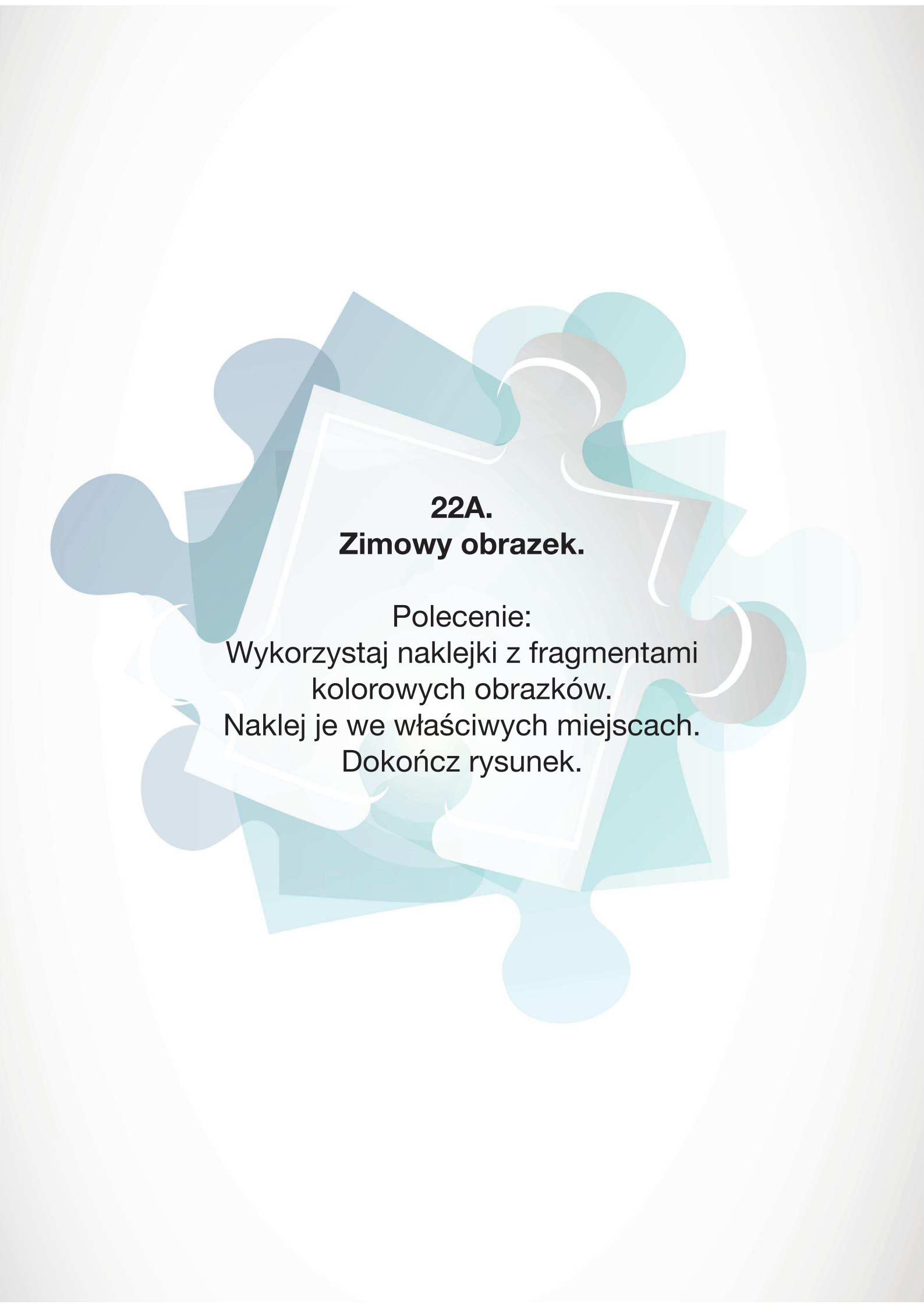
**22A.**  
**Zimowy obrazek.**

Polecenie:  
Wykorzystaj naklejki z fragmentami  
kolorowych obrazków.  
Naklej je we właściwych miejscach.  
Dokończ rysunek.

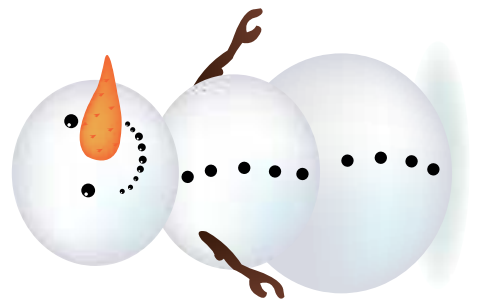
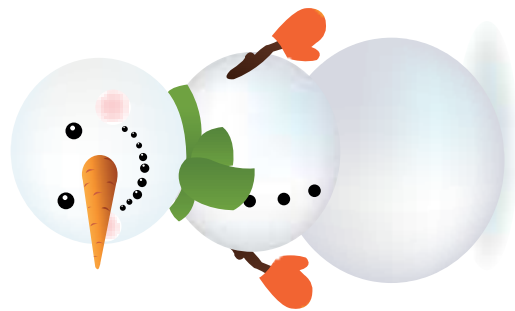
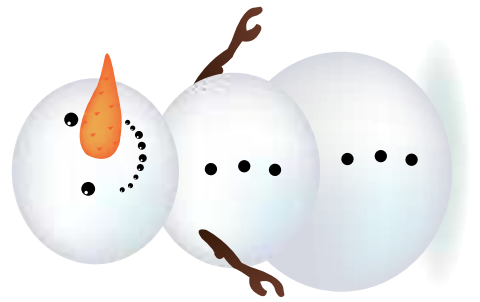
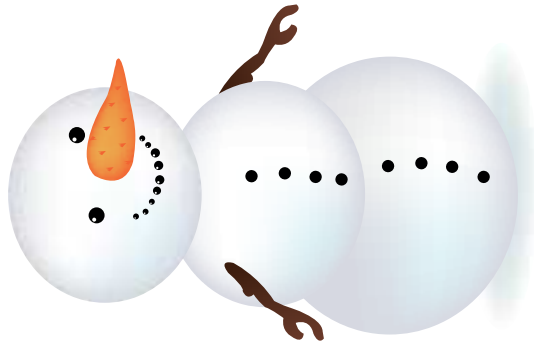
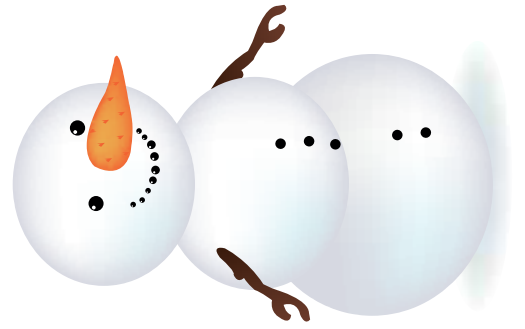
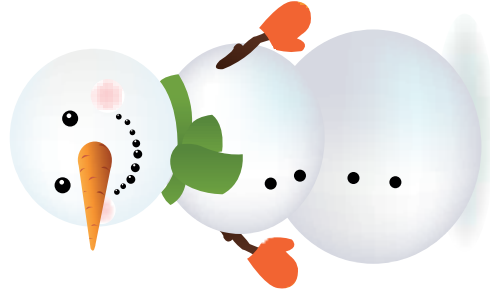
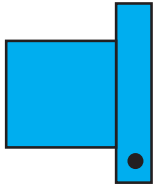
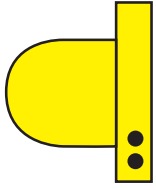
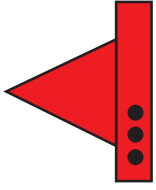
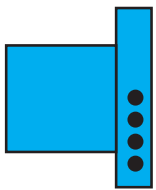
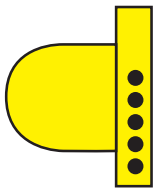
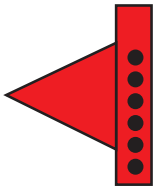
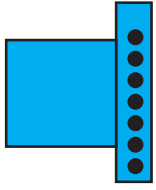
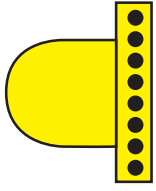
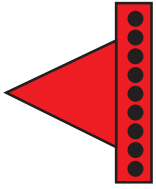

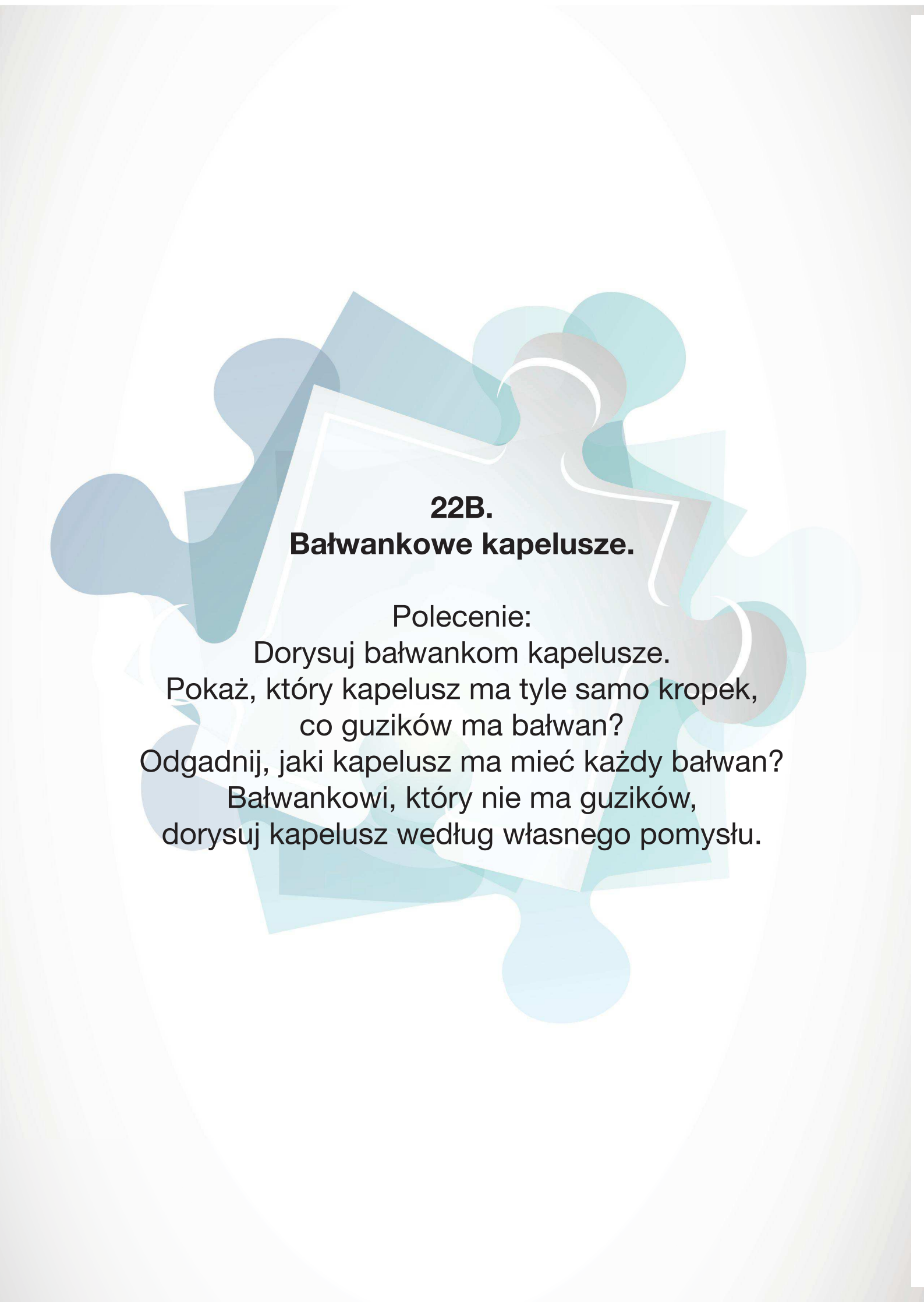

**22B.**  
**Baławankowe kapelusze.**

Polecenie:

Dorysuj baławankom kapelusze.

Pokaż, który kapelusz ma tyle samo kropek,  
co guzików ma bałwan?

Odgadnij, jaki kapelusz ma mieć każdy bałwan?

Baławankowi, który nie ma guzików,  
dorysuj kapelusz według własnego pomysłu.







**23A.**  
**Kukielka.**

Polecenie:  
Zaprojektuj kukielkę z drewnianej łyżki.  
Wykorzystaj kredki,  
farby, skrawki materiału, bibuły, ...

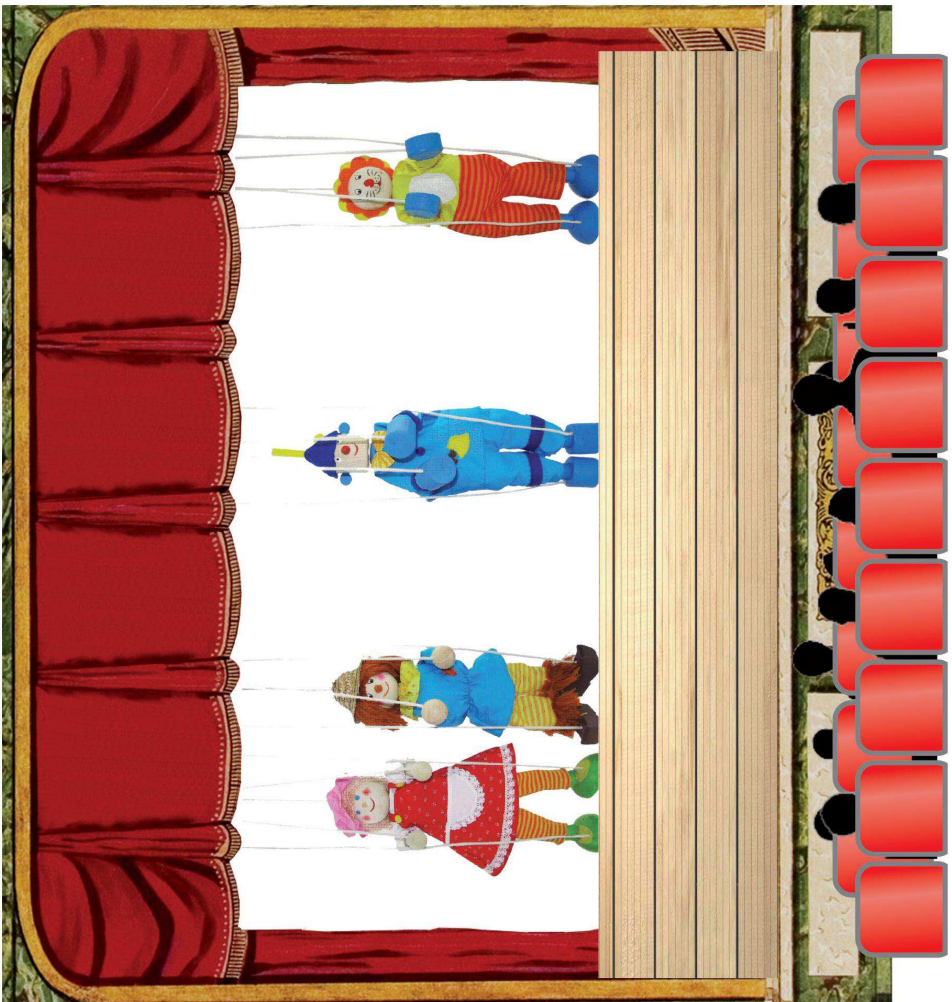
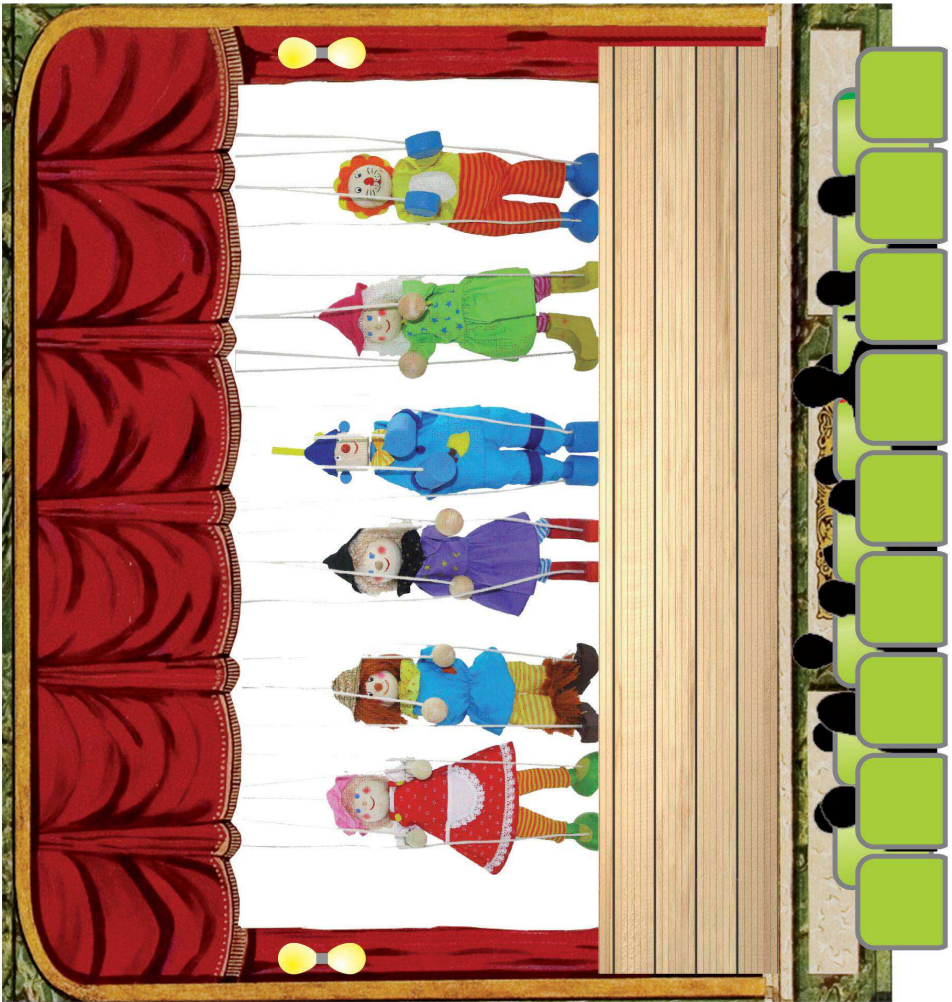

Handwriting practice lines for the letter 'N'. The first line shows a dashed 'N' for tracing. The second line shows a solid 'N' with an arrow indicating the starting point and direction of the stroke.



**23B.**  
**Teatr-różnice.**

Polecenie:  
Odszukaj różnice na obrazkach  
i zaznacz je czerwonymi kropkami.



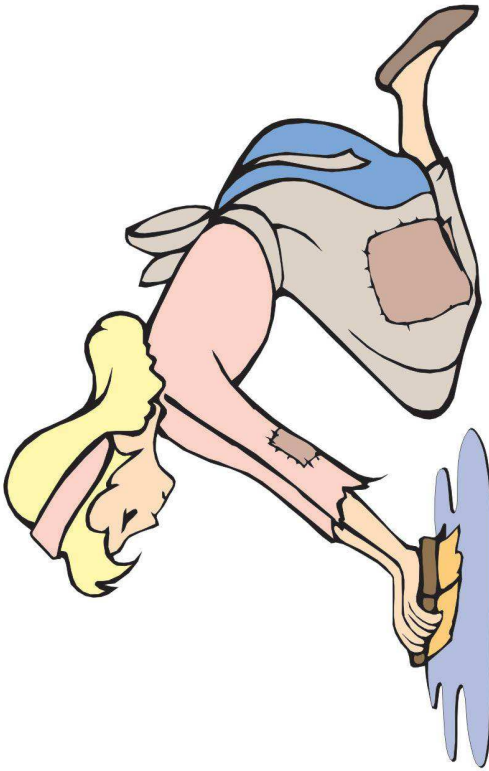
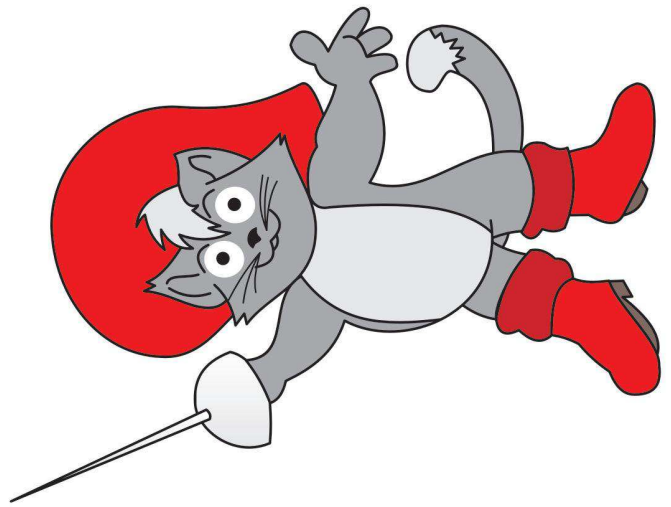



**24A.  
Bajki.**

Polecenie:

Otocz zieloną pętlą bajkowych bohaterów,  
którzy kojarzą ci się z dobrem,  
a czarną te postaci, które są złe.  
Uzasadnij swój wybór.



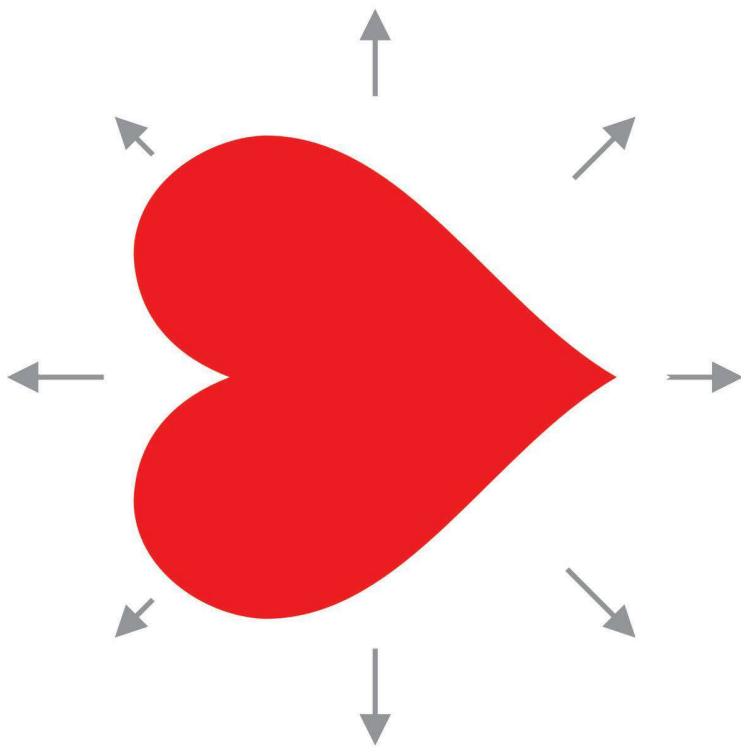

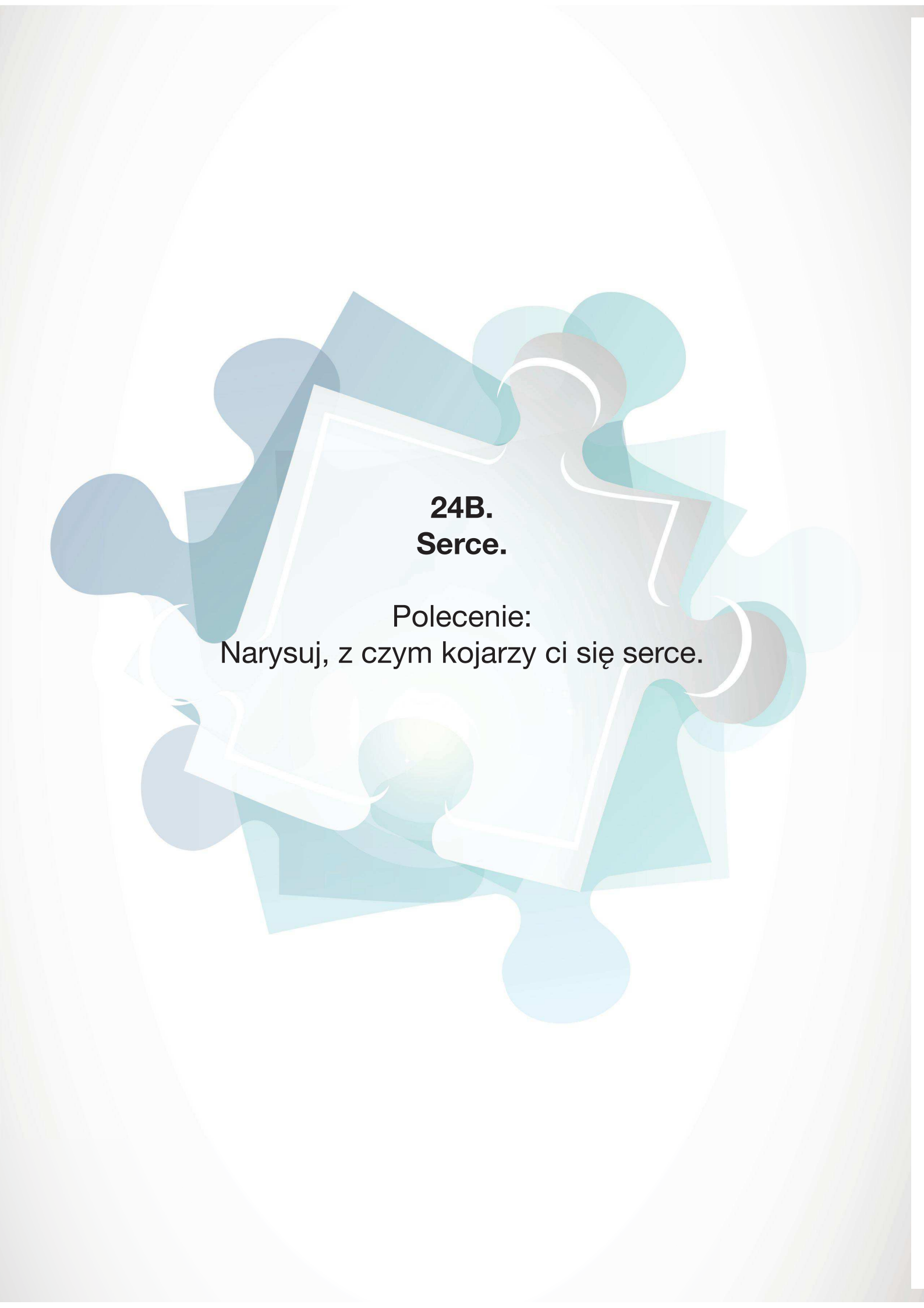

**24B.  
Serce.**

Polecenie:  
Narysuj, z czym kojarzy ci się serce.





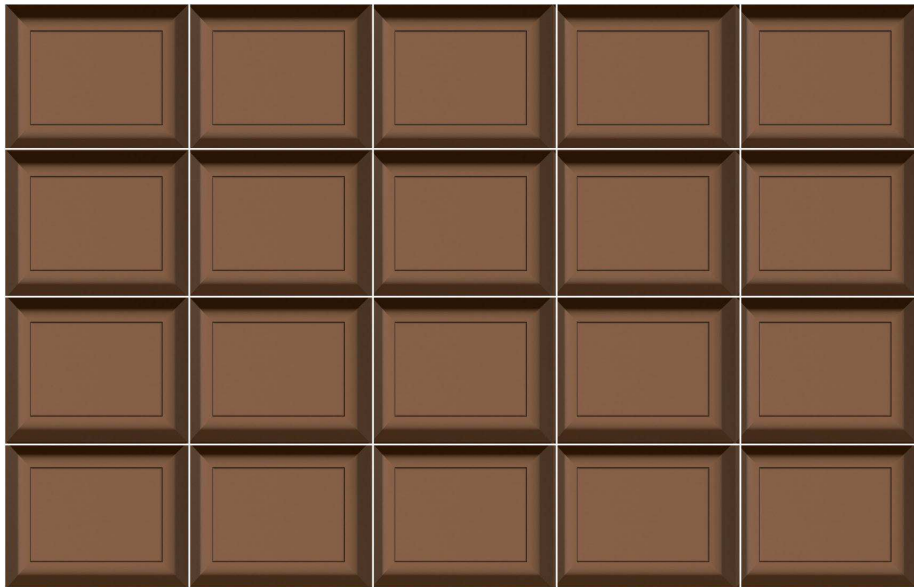



**24C.**  
**Czekolada.**

Polecenie:  
Podziel (wytnij) czekoladę tak,  
aby na każdym talerzu było  
po tyle samo kostek.



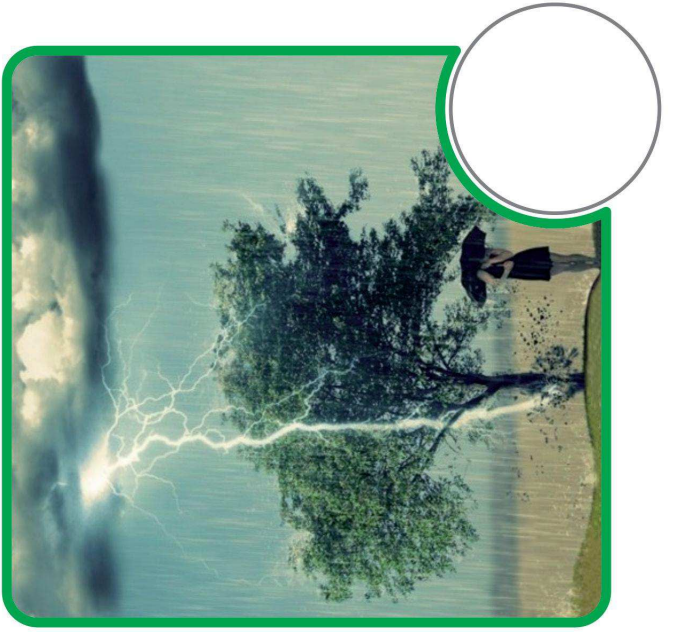
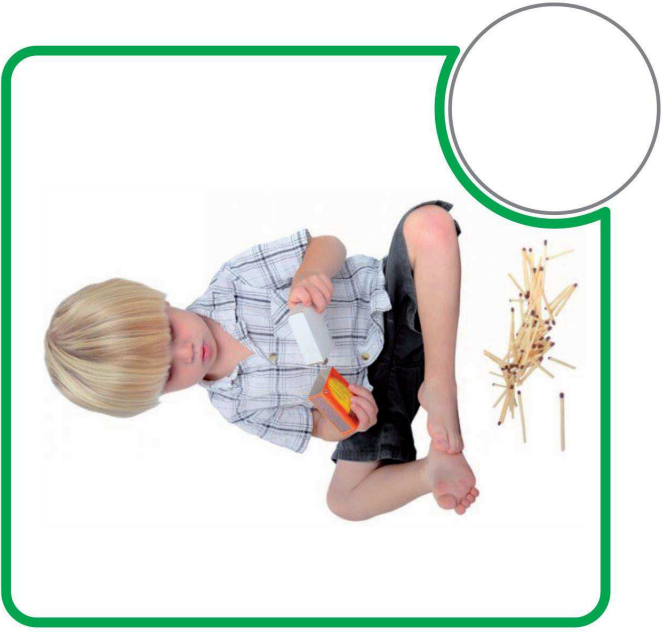



**24D.**  
**Dobre postępowanie.**

Polecenie:  
Opowiedz co widzisz na obrazkach  
i oceń zachowanie dzieci,  
przyklejając właściwą naklejkę.

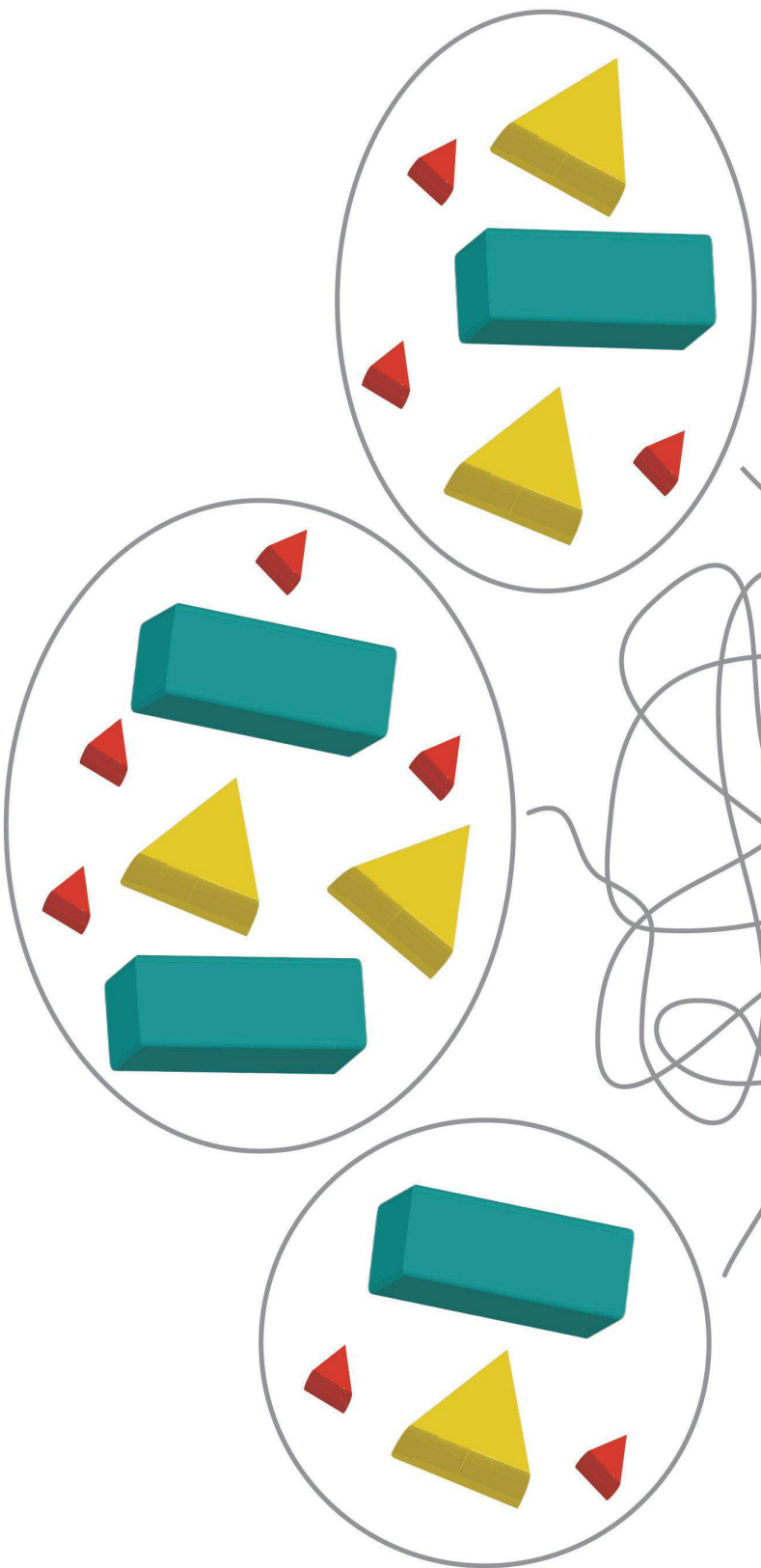
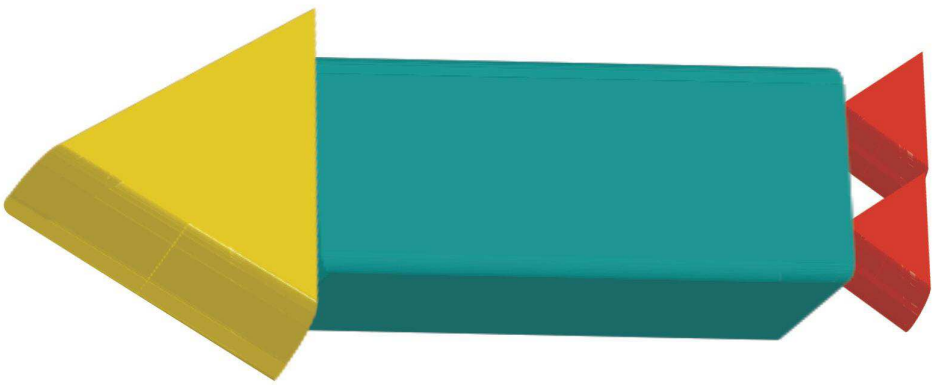

Olek



Ewa



Adam



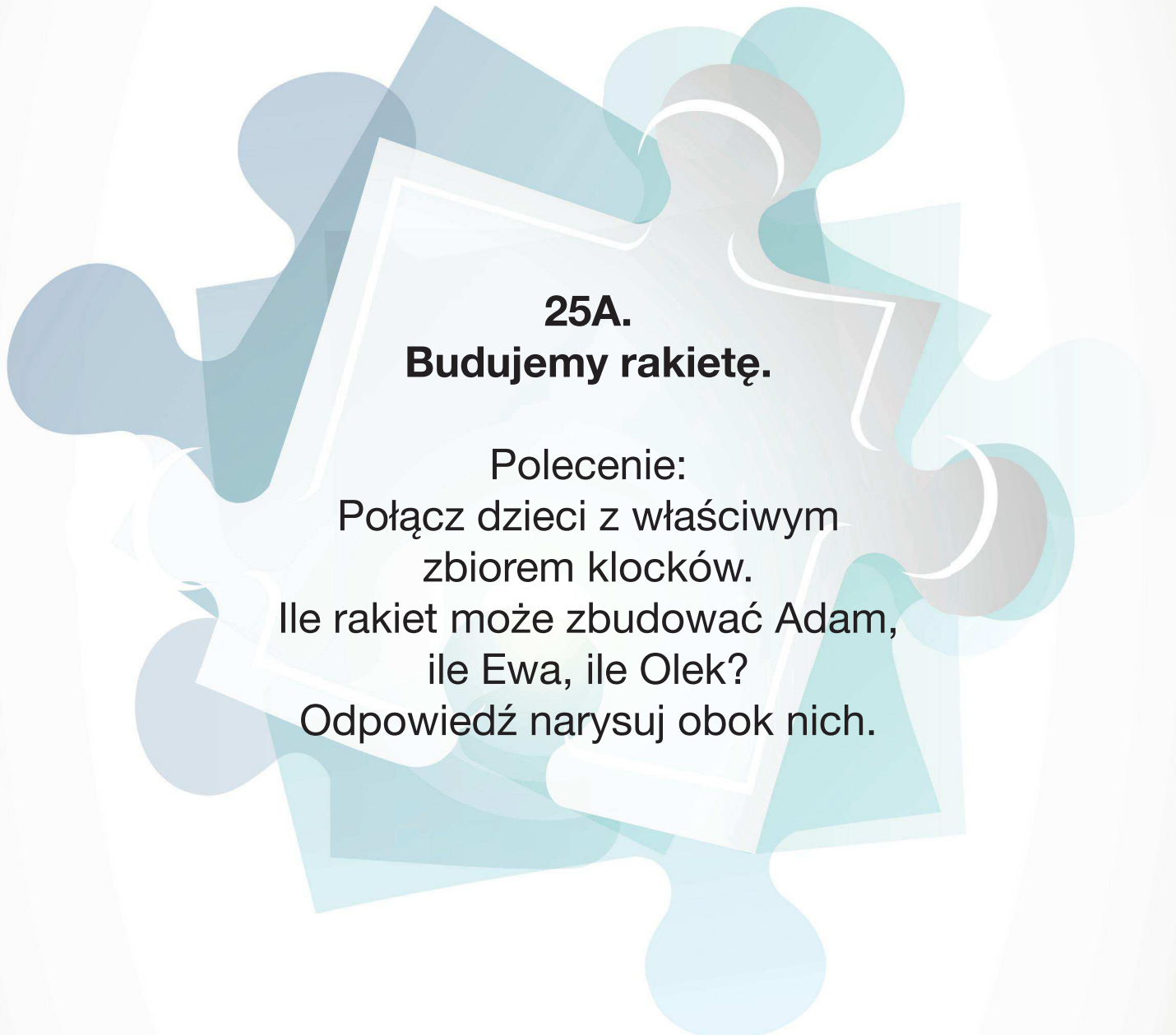

**25A.**  
**Budujemy raketę.**

Polecenie:  
Połącz dzieci z właściwym  
zbiorem klocków.  
Ile raket może zbudować Adam,  
ile Ewa, ile Olek?  
Odpowiedź narysuj obok nich.

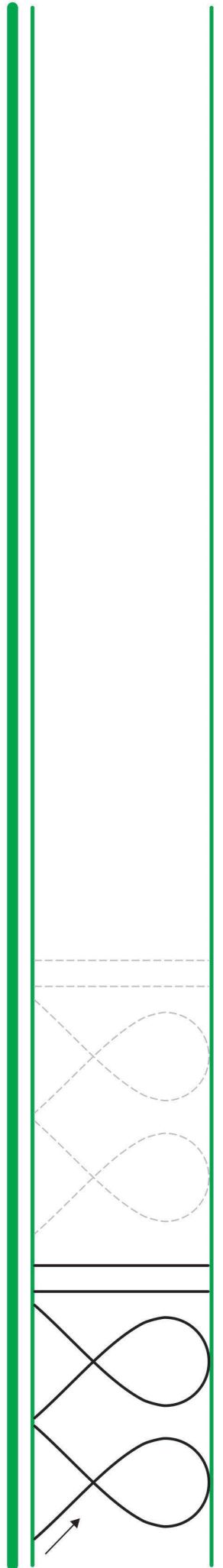



**25B.**  
**Kosmos-różnice.**

Polecenie:  
Znajdź i zaznacz różnice na obrazkach.  
Dokończ szlaczek.







**KAPITAŁ LUDZKI**  
NARODOWA STRATEGIA SPÓJNOŚCI

**INBIT**  
KOMPETENCJE TWORZA MOŻLIWOŚCI

**EFADOS**  
SIŁA WOMIR. ANIOŁ

**UNIA EUROPEJSKA**  
EUROPEJSKI  
FUNDUSZ SPOŁECZNY



Projekt współfinansowany ze środków Unii Europejskiej w ramach Europejskiego Funduszu Społecznego.