



**KAPITAŁ LUDZKI**  
NARODOWA STRATEGIA SPÓJNOŚCI



**UNIA EUROPEJSKA**  
EUROPEJSKI  
FUNDUSZ SPOŁECZNY



Projekt współfinansowany przez Unię Europejską w ramach Europejskiego Funduszu Społecznego

# Matematyka w sztuce – zasady tworzenia obrazów anamorficznych

- Ada Pałka
  - Instytut Matematyki
- Wydział Matematyki i Informatyki
  - Uniwersytet Jagielloński



Projekt realizowany przez Uniwersytet Rzeszowski w partnerstwie z Uniwersytetem Jagiellońskim oraz Państwową Wyższą Szkołą Zawodową w Chełmie



# Plan

- Definicja
- Rys historyczny
- Własności i zasada konstrukcyjna rzutu anamorficznego
- Przykłady
- Zastosowanie



# Holbein *Ambasadorowie* (1533)

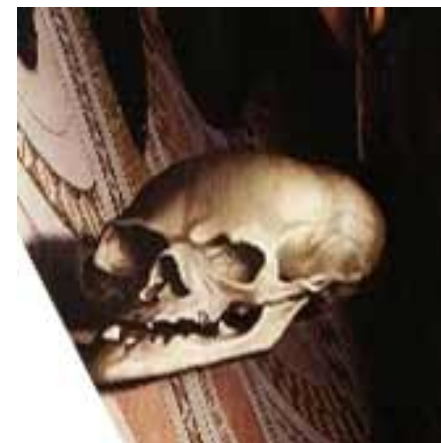



## Definicja

/Encyklopedia Diderota/ (1751)

„W malarstwie anamorfoza oznacza wynaturzone rzutowanie albo zdeformowane przedstawienie kilku obrazów na płaszczyźnie, które jednak z pewnego punktu widzenia okazuje się regularne i wykonane według właściwych proporcji.”



KAPITAŁ LUDZKI  
NARODOWA STRATEGIA SPÓJNOŚCI



UNIA EUROPEJSKA  
EUROPEJSKI  
FUNDUSZ SPOŁECZNY



# Narodziny i okres upowszechnienia XVI w



lifl.fr

Leonardo da Vinci, *CODEX ATLANTICUS*, 1483-1518



KAPITAŁ LUDZKI  
NARODOWA STRATEGIA SPÓJNOŚCI

Uniwersytety  
M U  
Matematyczne  
Wzajemne

UNIA EUROPEJSKA  
EUROPEJSKI  
FUNDUSZ SPOŁECZNY



# Perspektywa linearna



Albrecht Dürer's *Draughtsman Making a Perspective Drawing of a Woman* (1525)

[anamorphicart.files.wordpress.com](http://anamorphicart.files.wordpress.com)



# Anamorfoza

(gr. *ana* – z powrotem; *morphe* – forma)

Perspektywa linearna

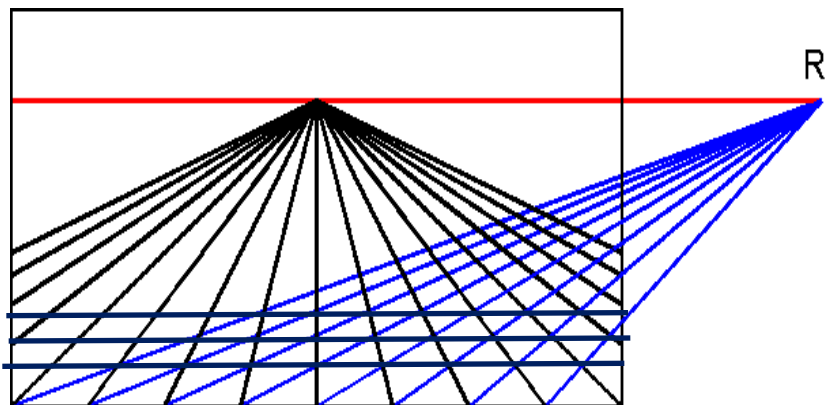

Anamorfoza płaszczyznowa

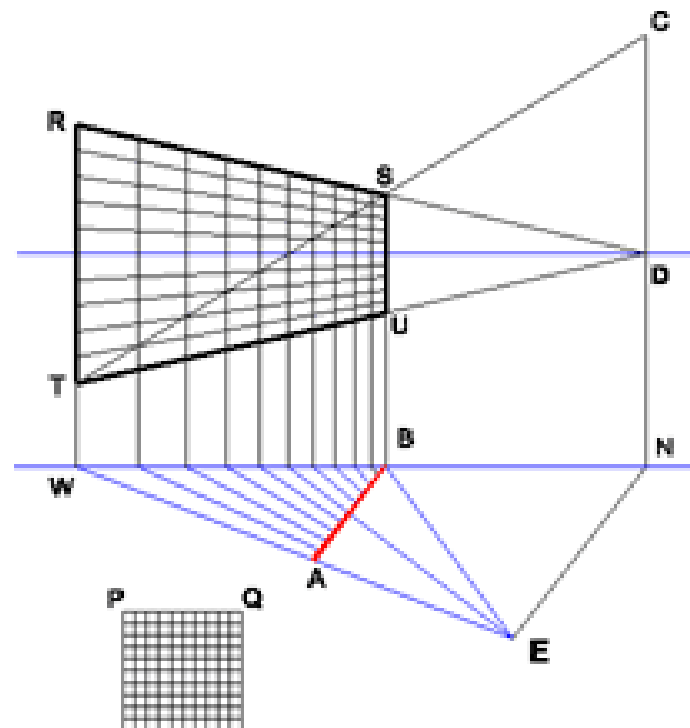

[anamorphicart.wordpress.com](http://anamorphicart.wordpress.com)





# Anamorfoza

- konsekwencja zasad perspektywy linearnej
  - pkt. zbiegu lini wychodzących z oka z dala od pkt. centralnego;
  - pkt. widzenia bardzo blisko płaszczyzny przedstawienia.





**KAPITAŁ LUDZKI**  
NARODOWA STRATEGIA SPÓJNOŚCI

Uniwersytety  
Młodzieżowe **M** **I** **U** **M** Matematyczne

**V**

**UNIA EUROPEJSKA**  
EUROPEJSKI  
FUNDUSZ SPOŁECZNY



n° 125 k-4



n° 125 k-4

LA  
**PERSPECTIVE**  
**CVRIEVSE**

DV

REVEREND P. NICERON  
MINIME.

*DIVISEE EN QUATRE LIVRES.*

AVEC

L'OPTIQUE ET LA CATOPTRIQUE  
du R. P. Merfenne du mesme Ordre, mise in lumiere  
après la mort de l'Auteur.

OEUVRE TRES-UTILE AVX PEINTRES,  
*Architectes, Sculpteurs, Graveurs, & à tous autres  
qui se meslent du Dessin.*



A PARIS;

Chez la veufue F. LANGLOIS, dit GHARTRES, rue  
S. Jacques, aux Colomnes d'Hercule.

M. DC. LII.

*Avec Privilège du Roy.*



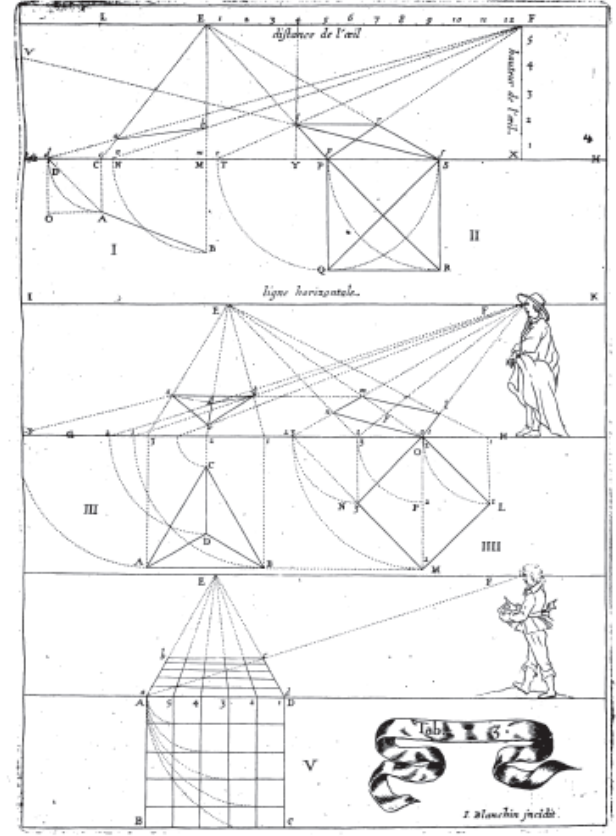
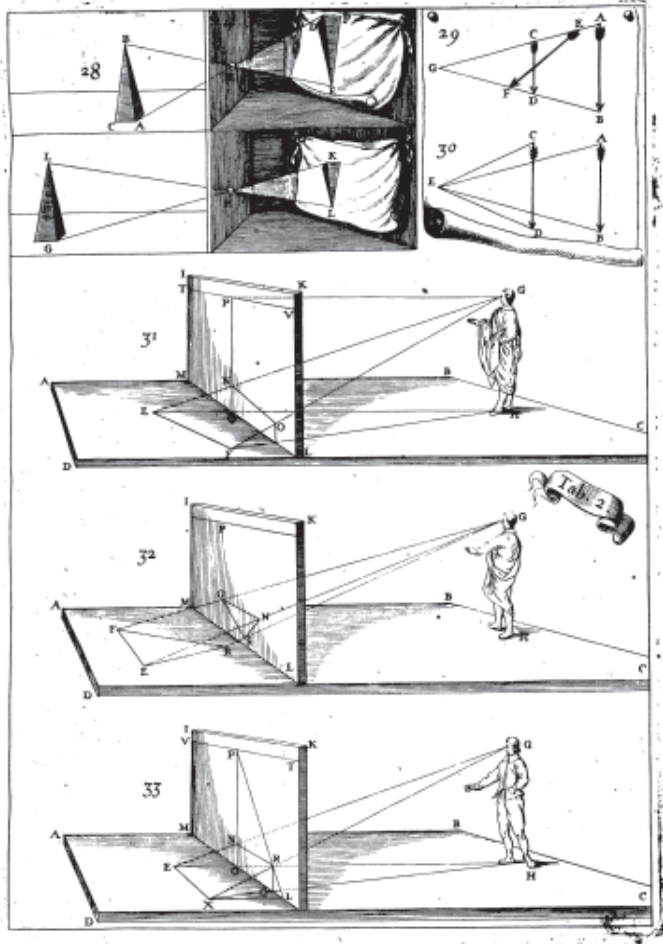

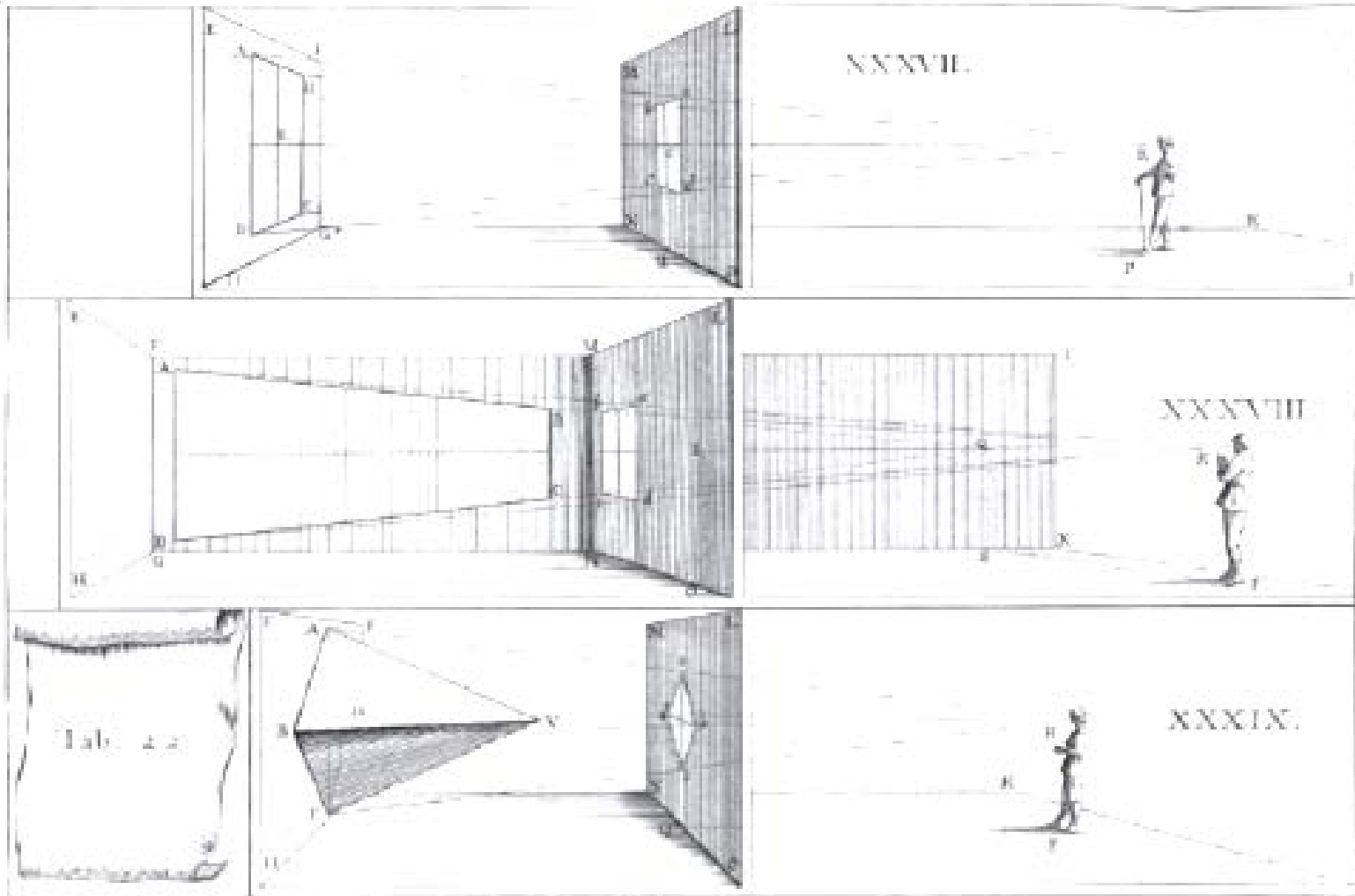



# Własności i zasada konstrukcyjna rzutu anamorficznego

- Anamorfozy perspektywiczne

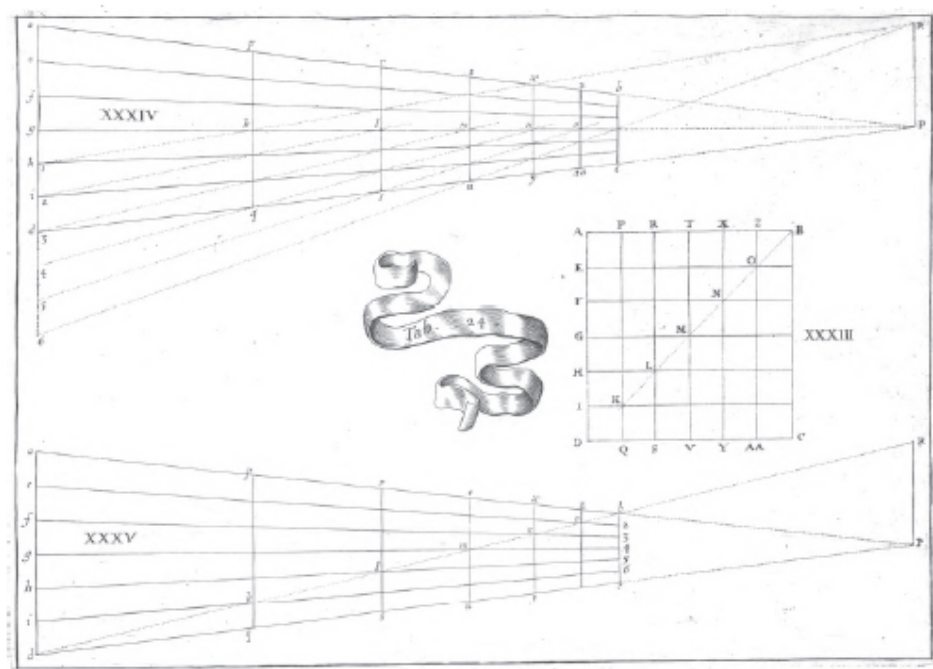



# Własności i zasada konstrukcyjna rzutu anamorficznego

- Anamorfozy perspektywiczne

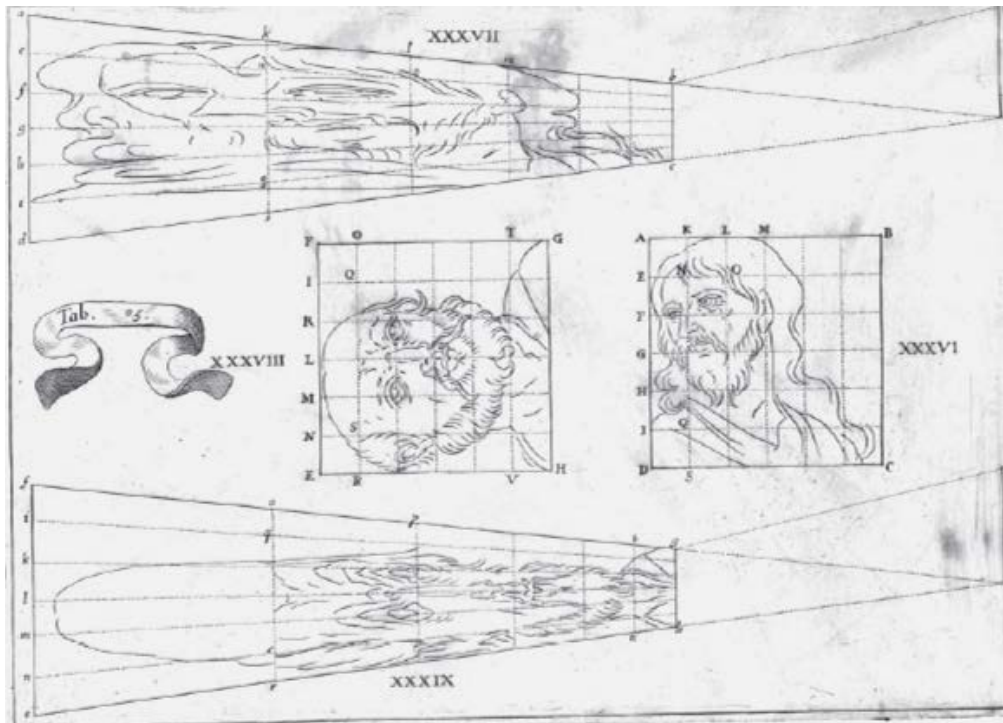





# Konstrukcja

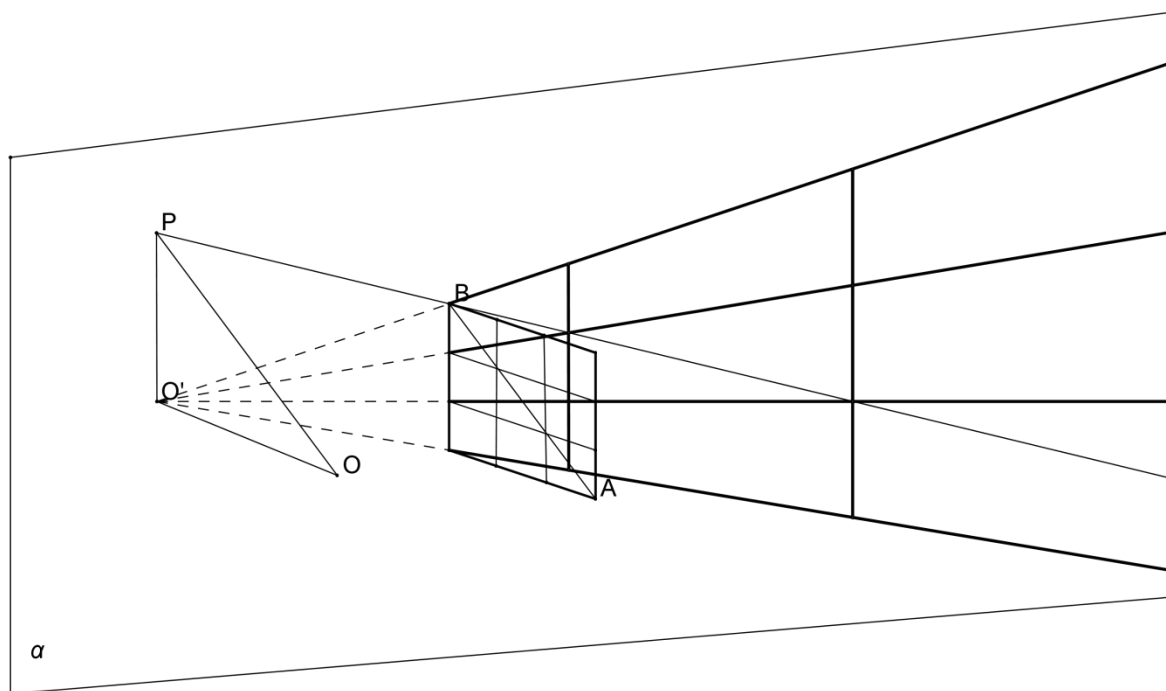



# Własności i zasada konstrukcyjna rzutu anamorficznego

- Anamorfozy refleksyjne – walcowe

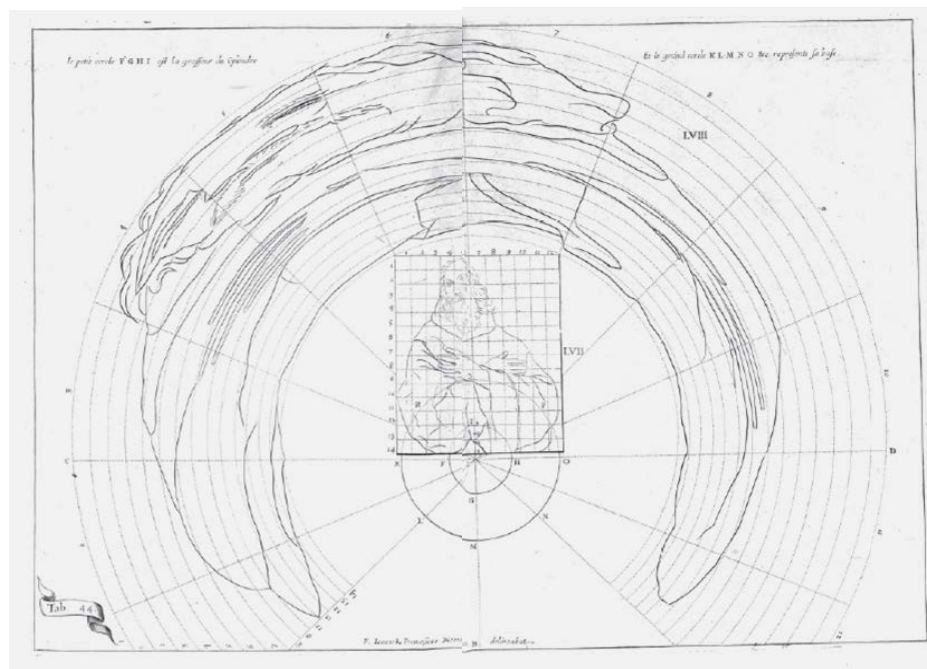





# Konstrukcja

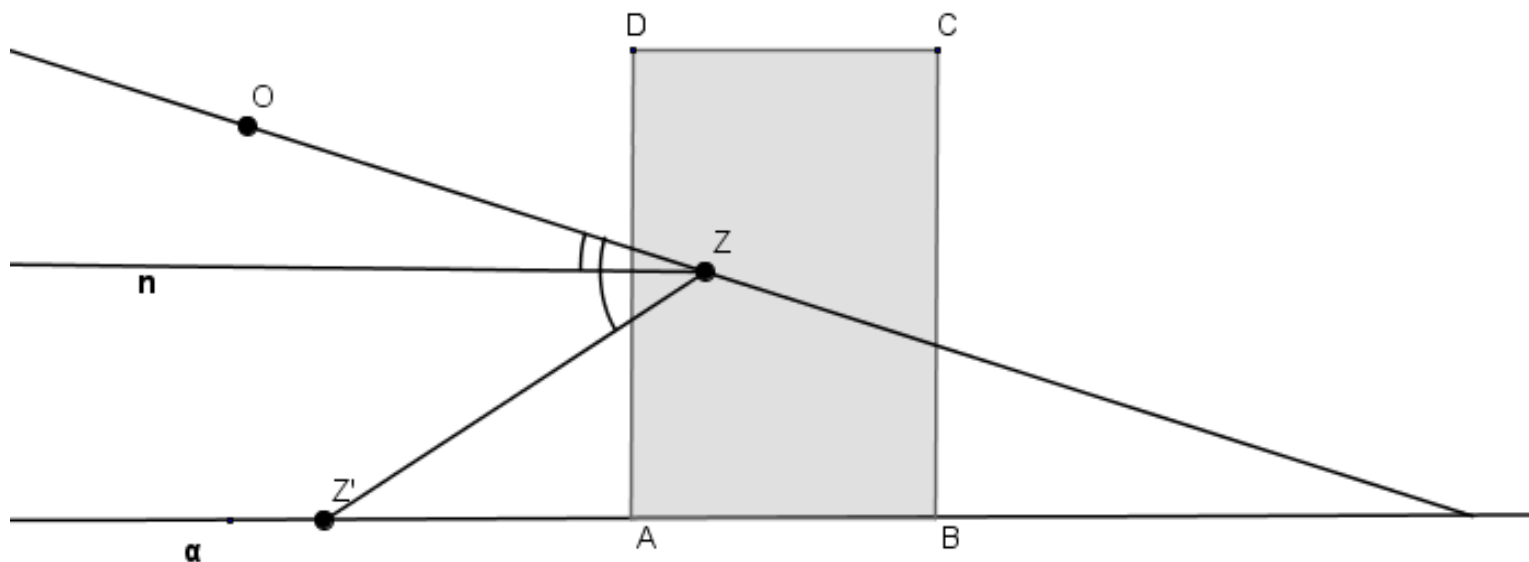



# Konstrukcja

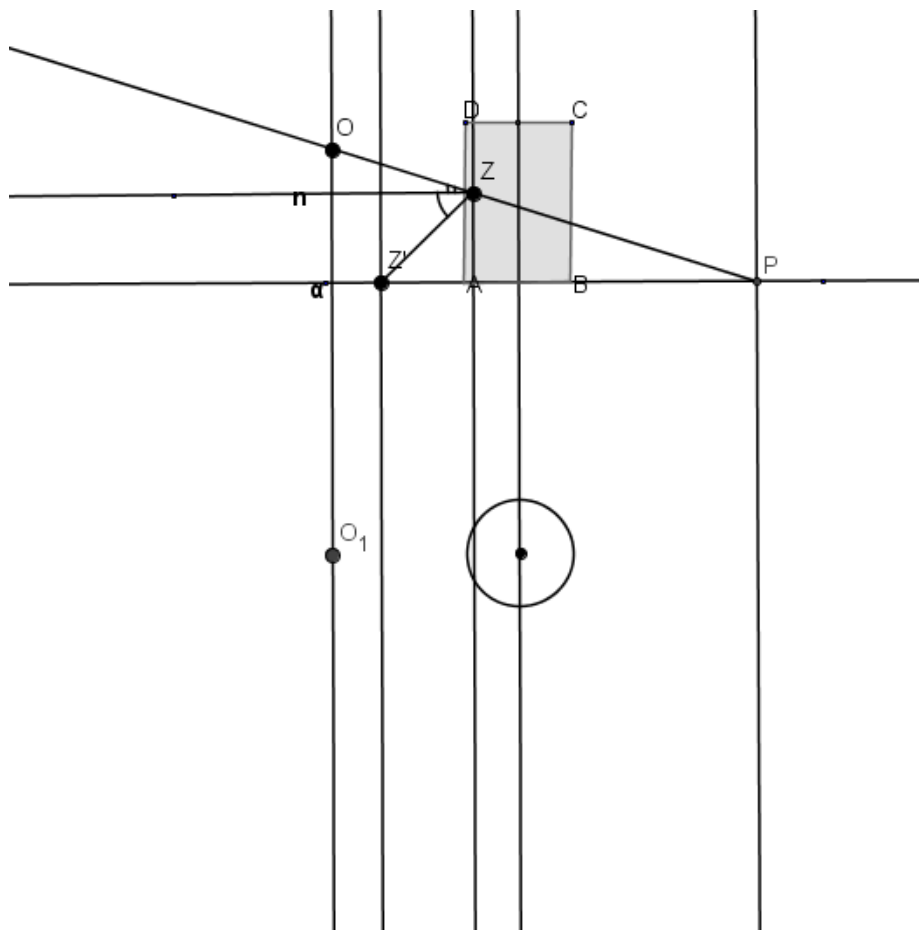



# Konstrukcja

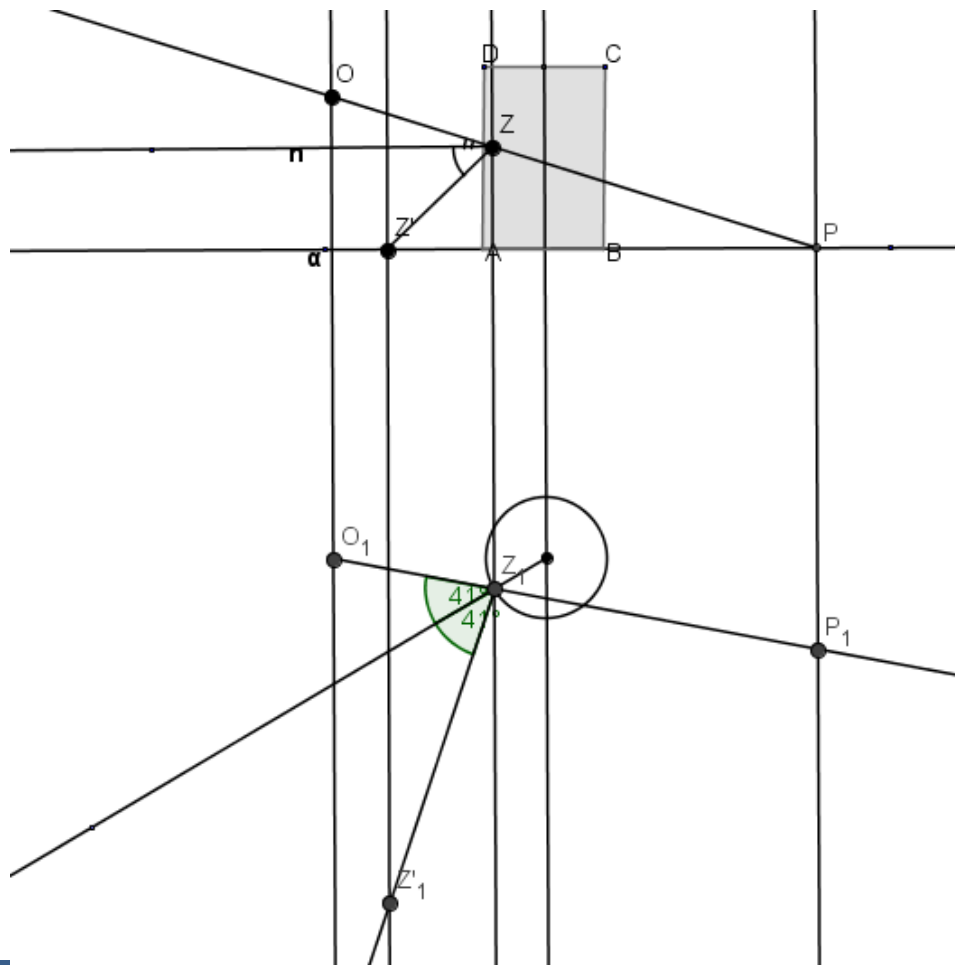



# Konstrukcja

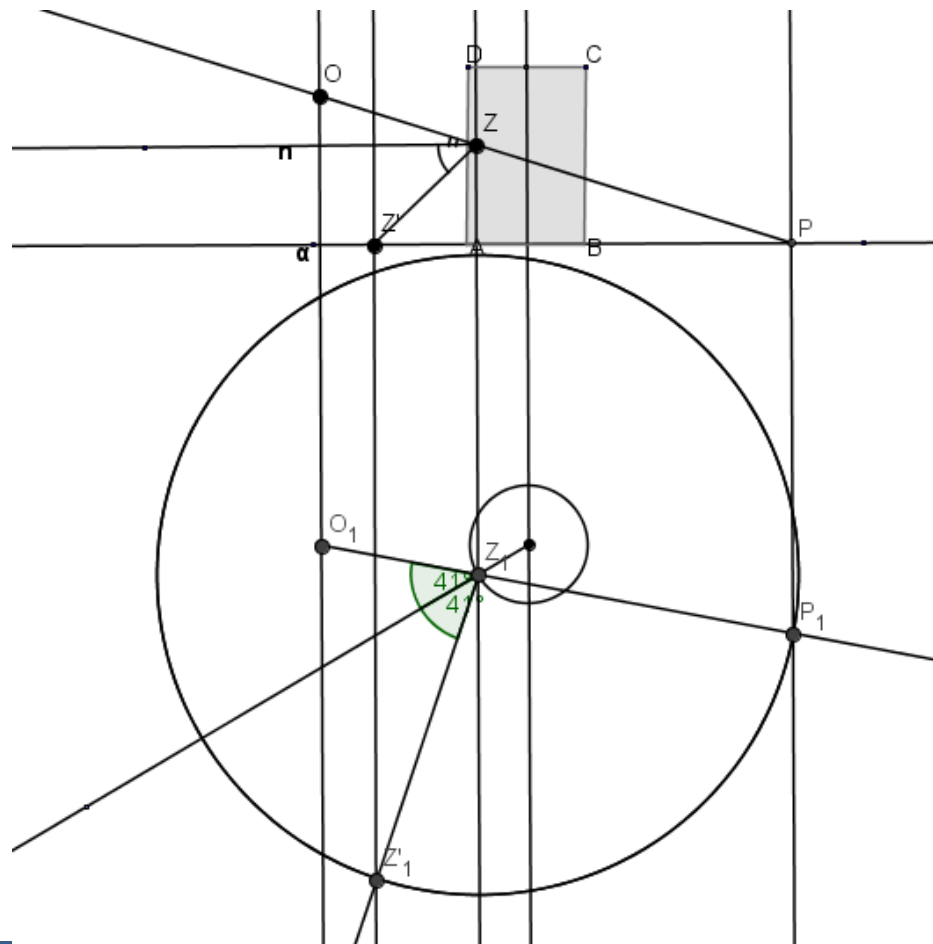





# Siatka deformacyjna

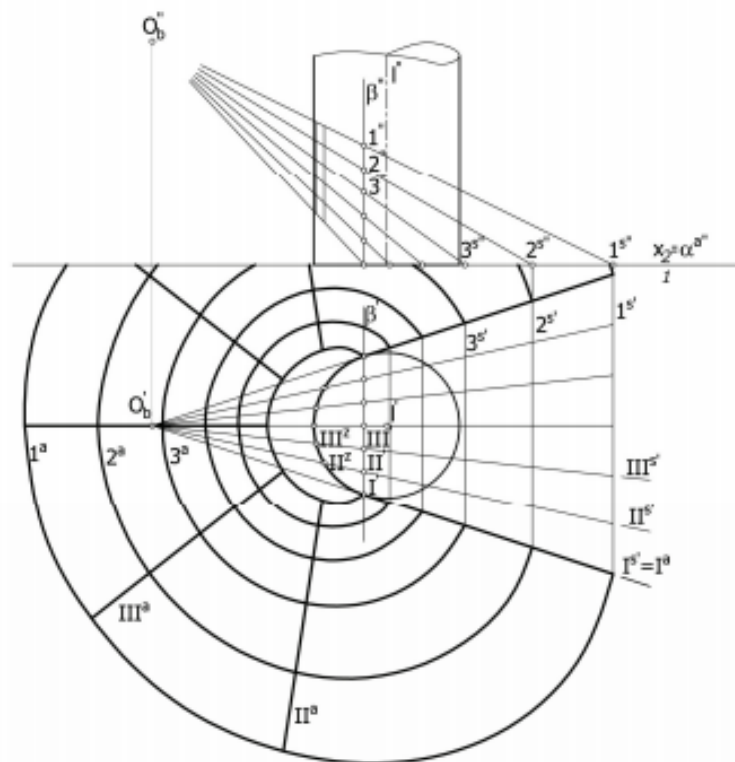



# Program AnamorphMe - Phillip Kent

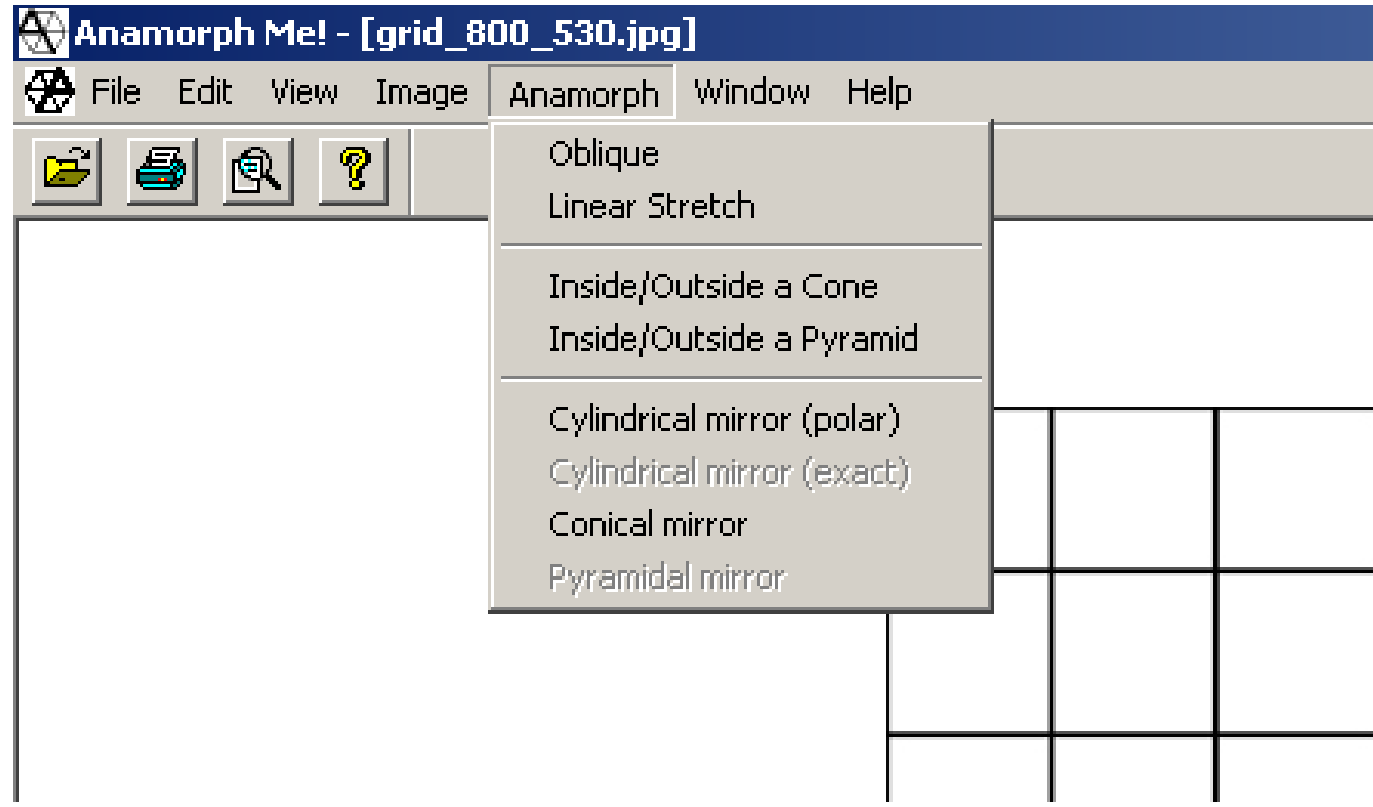





# "Anamorph Me!"

Copyright Phillip Kent 2001.

The program is based on  
the following copyrighted code:

- \* Paintlib C++ class library, copyright Ulrich von Zadow, 1996-2000
- \* "Piclook" application, copyright Bernard Delmee, 1998



KAPITAŁ LUDZKI  
NARODOWA STRATEGIA SPÓJNOŚCI



UNIA EUROPEJSKA  
EUROPEJSKI  
FUNDUSZ SPOŁECZNY



# Przykłady z AnamorphME

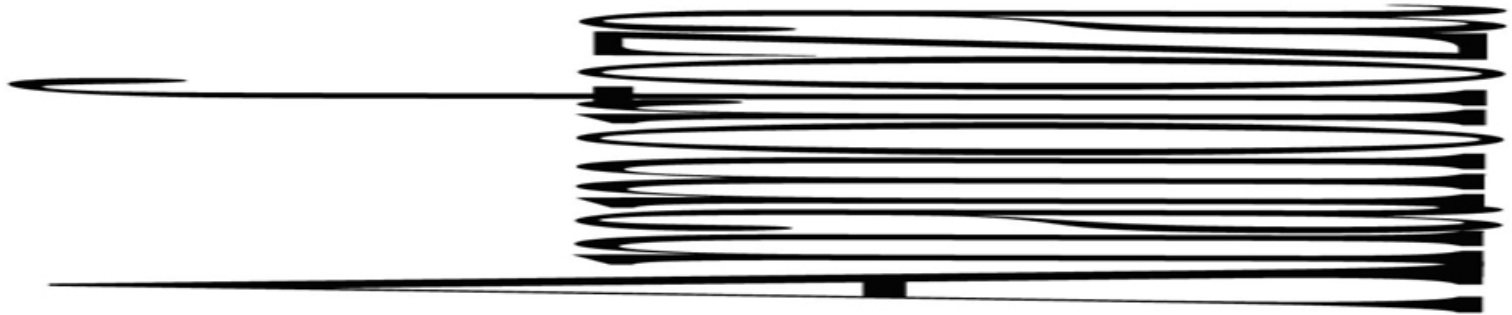



**KAPITAŁ LUDZKI**  
NARODOWA STRATEGIA SPÓJNOŚCI



**UNIA EUROPEJSKA**  
EUROPEJSKI  
FUNDUSZ SPOŁECZNY



# Przykłady z AnamorphME





**KAPITAŁ LUDZKI**  
NARODOWA STRATEGIA SPÓJNOŚCI



**UNIA EUROPEJSKA**  
EUROPEJSKI  
FUNDUSZ SPOŁECZNY



# Przykłady z AnamorphME







# Przykłady z AnamorphME

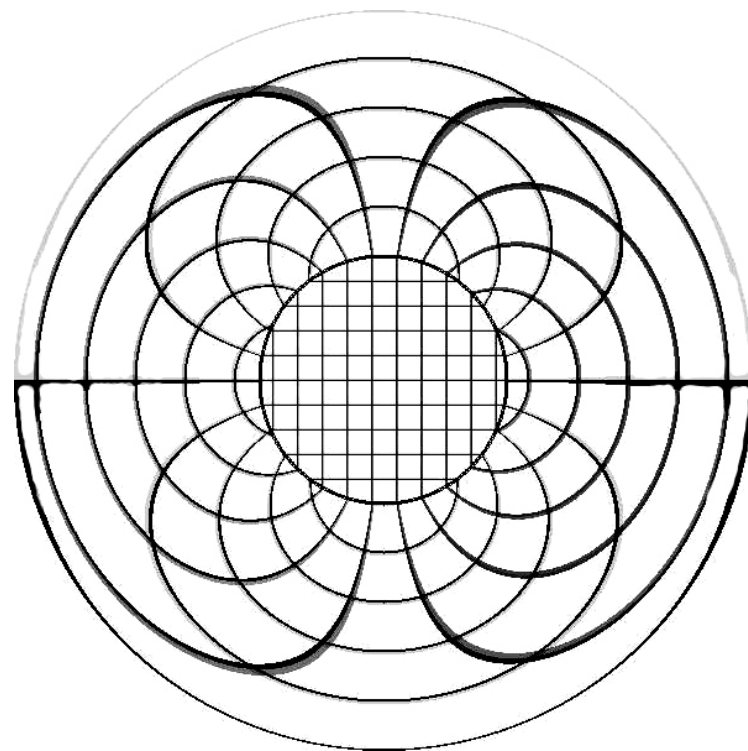



**KAPITAŁ LUDZKI**  
NARODOWA STRATEGIA SPÓJNOŚCI



**UNIA EUROPEJSKA**  
EUROPEJSKI  
FUNDUSZ SPOŁECZNY



# Przykłady anamorfoz perspektywicznych (płaszczyznowych)



KAPITAŁ LUDZKI  
NARODOWA STRATEGIA SPÓJNOŚCI



UNIA EUROPEJSKA  
EUROPEJSKI  
FUNDUSZ SPOŁECZNY



# Erhard Schön *Erotyka* (1535)



[www.exploramuseum.de](http://www.exploramuseum.de)

Projekt realizowany przez Uniwersytet Rzeszowski w partnerstwie z Uniwersytetem Jagiellońskim oraz Państwową Wyższą Szkołą Zawodową w Chełmie





**KAPITAŁ LUDZKI**  
NARODOWA STRATEGIA SPÓJNOŚCI



**UNIA EUROPEJSKA**  
EUROPEJSKI  
FUNDUSZ SPOŁECZNY

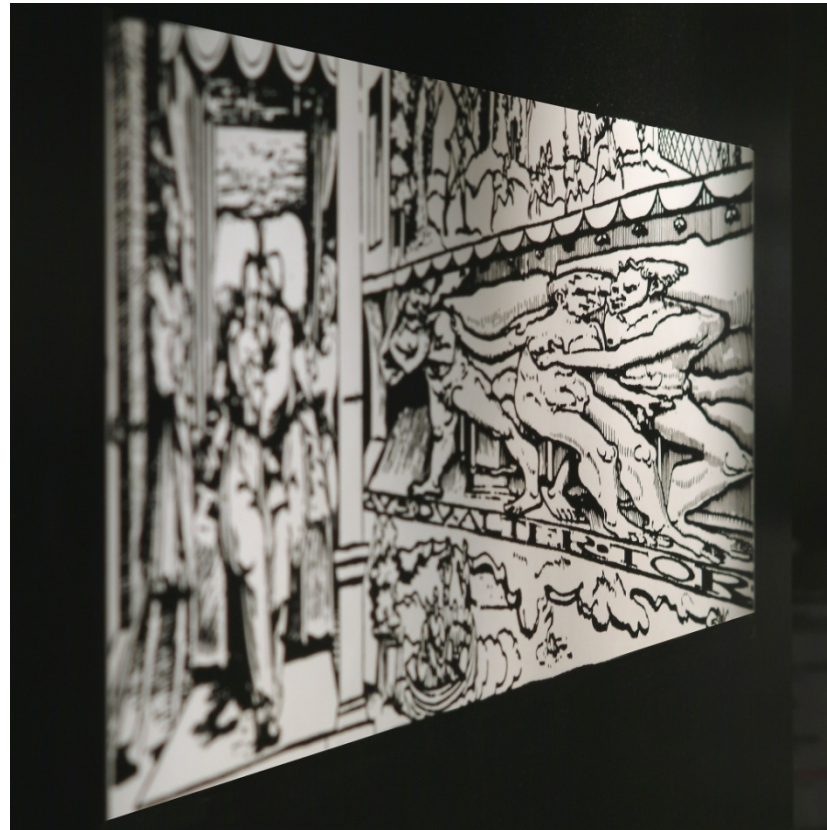



**KAPITAŁ LUDZKI**  
NARODOWA STRATEGIA SPÓJNOŚCI



**UNIA EUROPEJSKA**  
EUROPEJSKI  
FUNDUSZ SPOŁECZNY



# Erhard Schön *Prorok Jonasz* (1538)

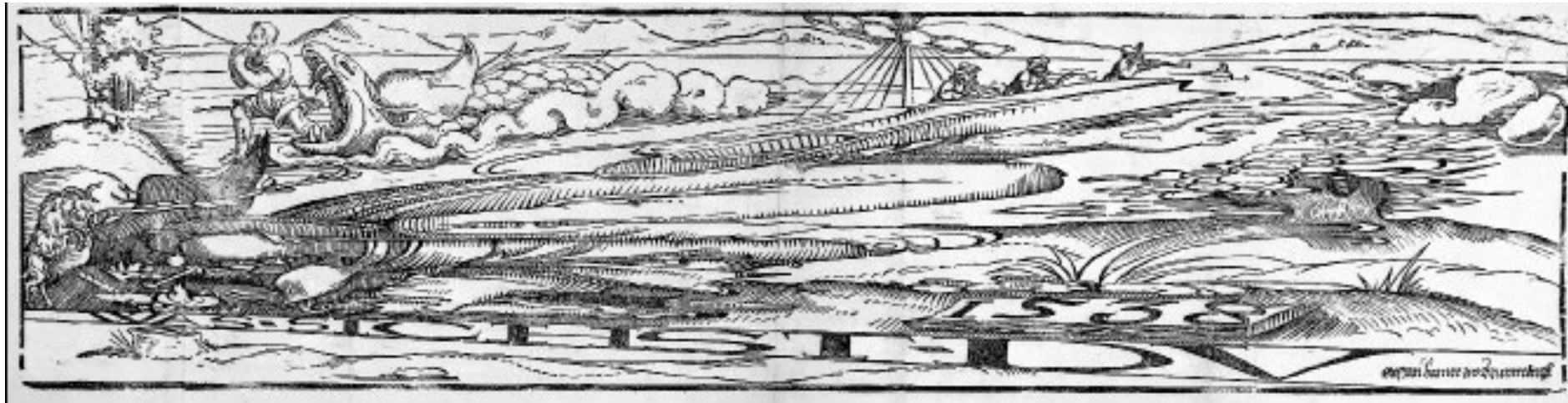



# Emmanuel Maignan

## *Św Franciszek z Paoli (1642,)*

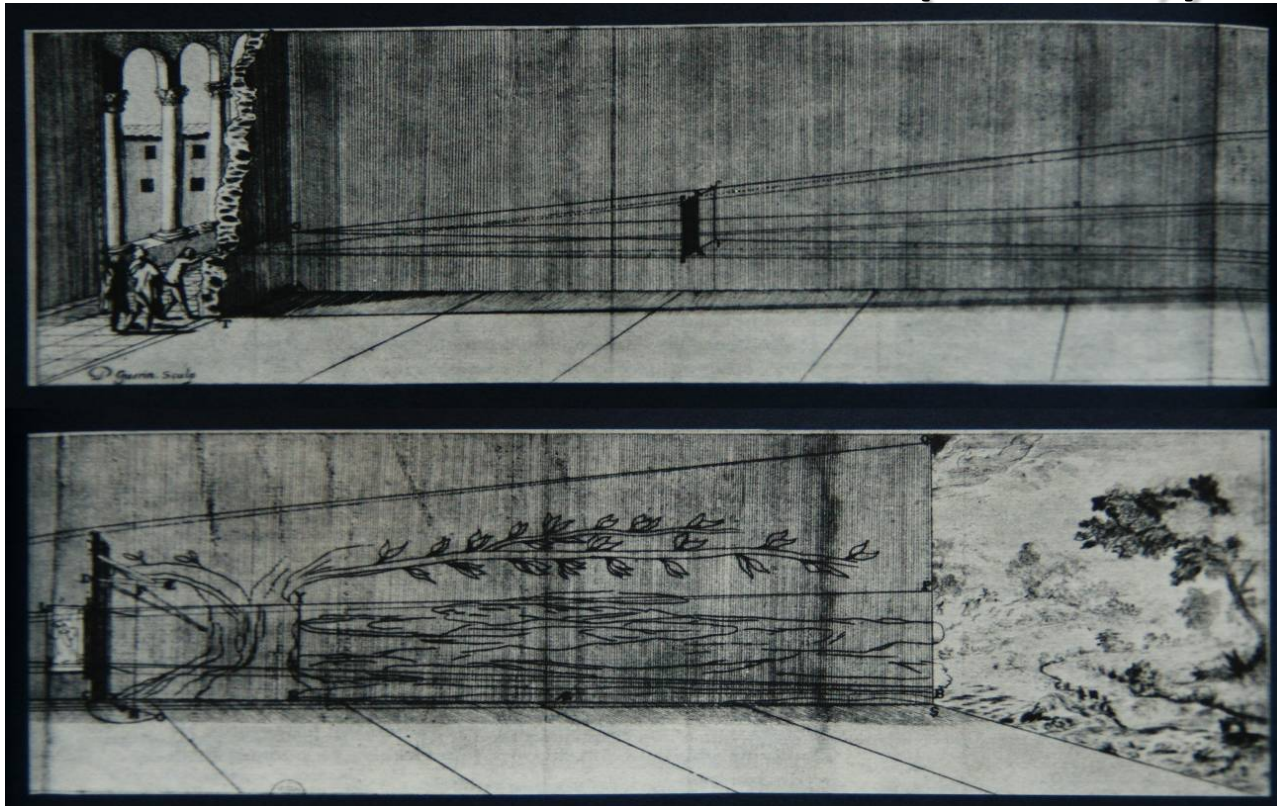





**KAPITAŁ LUDZKI**  
NARODOWA STRATEGIA SPÓJNOŚCI



**UNIA EUROPEJSKA**  
EUROPEJSKI  
FUNDUSZ SPOŁECZNY



Projekt realizowany przez Uniwersytet Rzeszowski w partnerstwie z Uniwersytetem Jagiellońskim oraz Państwową Wyższą Szkołą Zawodową w Chełmie



**KAPITAŁ LUDZKI**  
NARODOWA STRATEGIA SPÓJNOŚCI



**UNIA EUROPEJSKA**  
EUROPEJSKI  
FUNDUSZ SPOŁECZNY



# François Abélanet

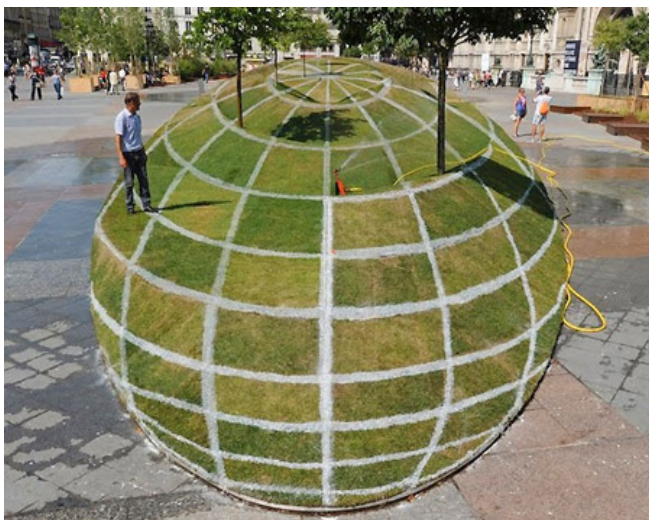





**KAPITAŁ LUDZKI**  
NARODOWA STRATEGIA SPÓJNOŚCI



**UNIA EUROPEJSKA**  
EUROPEJSKI  
FUNDUSZ SPOŁECZNY



# Istvan Orosz

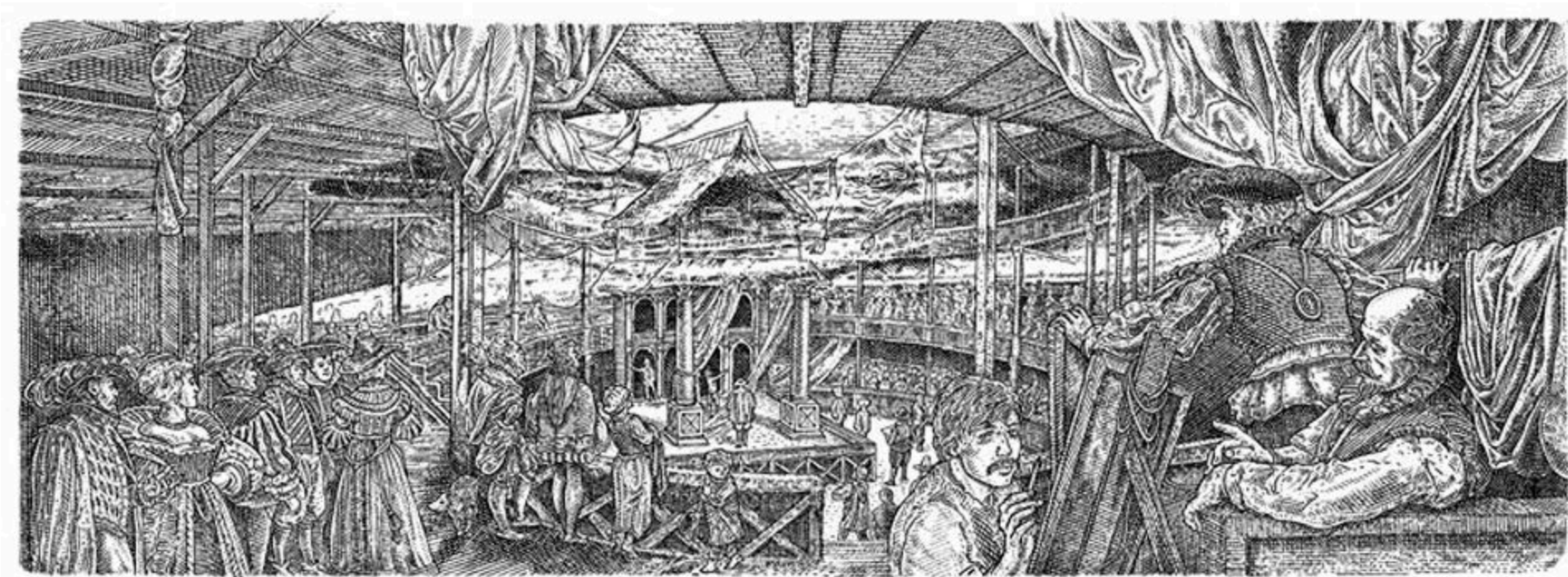



**KAPITAŁ LUDZKI**  
NARODOWA STRATEGIA SPÓJNOŚCI



**UNIA EUROPEJSKA**  
EUROPEJSKI  
FUNDUSZ SPOŁECZNY



# Istvan Orosz

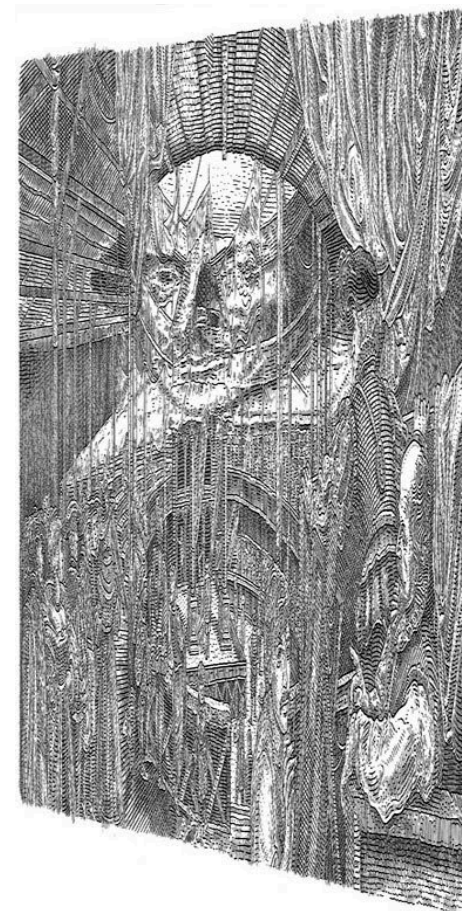





KAPITAŁ LUDZKI  
NARODOWA STRATEGIA SPÓJNOŚCI



UNIA EUROPEJSKA  
EUROPEJSKI  
FUNDUSZ SPOŁECZNY



# Kurt Wenner







**KAPITAŁ LUDZKI**  
NARODOWA STRATEGIA SPÓJNOŚCI



**UNIA EUROPEJSKA**  
EUROPEJSKI  
FUNDUSZ SPOŁECZNY



# Kurt Wenner





**KAPITAŁ LUDZKI**  
NARODOWA STRATEGIA SPÓJNOŚCI



**UNIA EUROPEJSKA**  
EUROPEJSKI  
FUNDUSZ SPOŁECZNY



# Znaki drogowe





**KAPITAŁ LUDZKI**  
NARODOWA STRATEGIA SPÓJNOŚCI



**UNIA EUROPEJSKA**  
EUROPEJSKI  
FUNDUSZ SPOŁECZNY



# Felice Varini

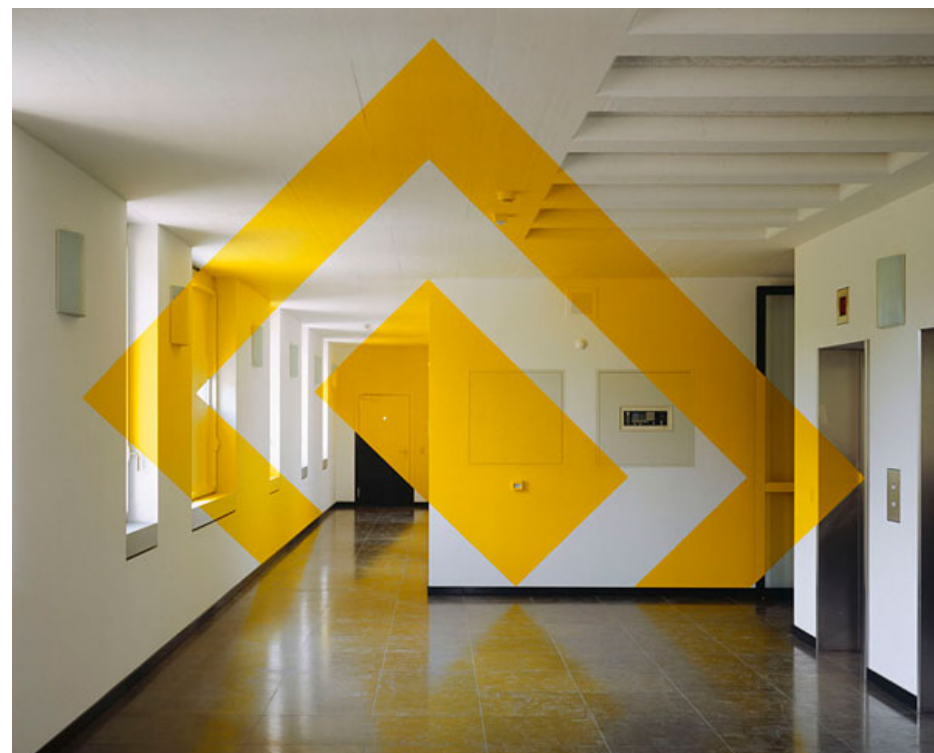



**KAPITAŁ LUDZKI**  
NARODOWA STRATEGIA SPÓJNOŚCI



**UNIA EUROPEJSKA**  
EUROPEJSKI  
FUNDUSZ SPOŁECZNY



# Felice Varini



Projekt realizowany przez Uniwersytet Rzeszowski w partnerstwie z Uniwersytetem Jagiellońskim oraz Państwową Wyższą Szkołą Zawodową w Chełmie





**KAPITAŁ LUDZKI**  
NARODOWA STRATEGIA SPÓJNOŚCI



**UNIA EUROPEJSKA**  
EUROPEJSKI  
FUNDUSZ SPOŁECZNY



# Felice Varini





**KAPITAŁ LUDZKI**  
NARODOWA STRATEGIA SPÓJNOŚCI



**UNIA EUROPEJSKA**  
EUROPEJSKI  
FUNDUSZ SPOŁECZNY



# Felice Varini

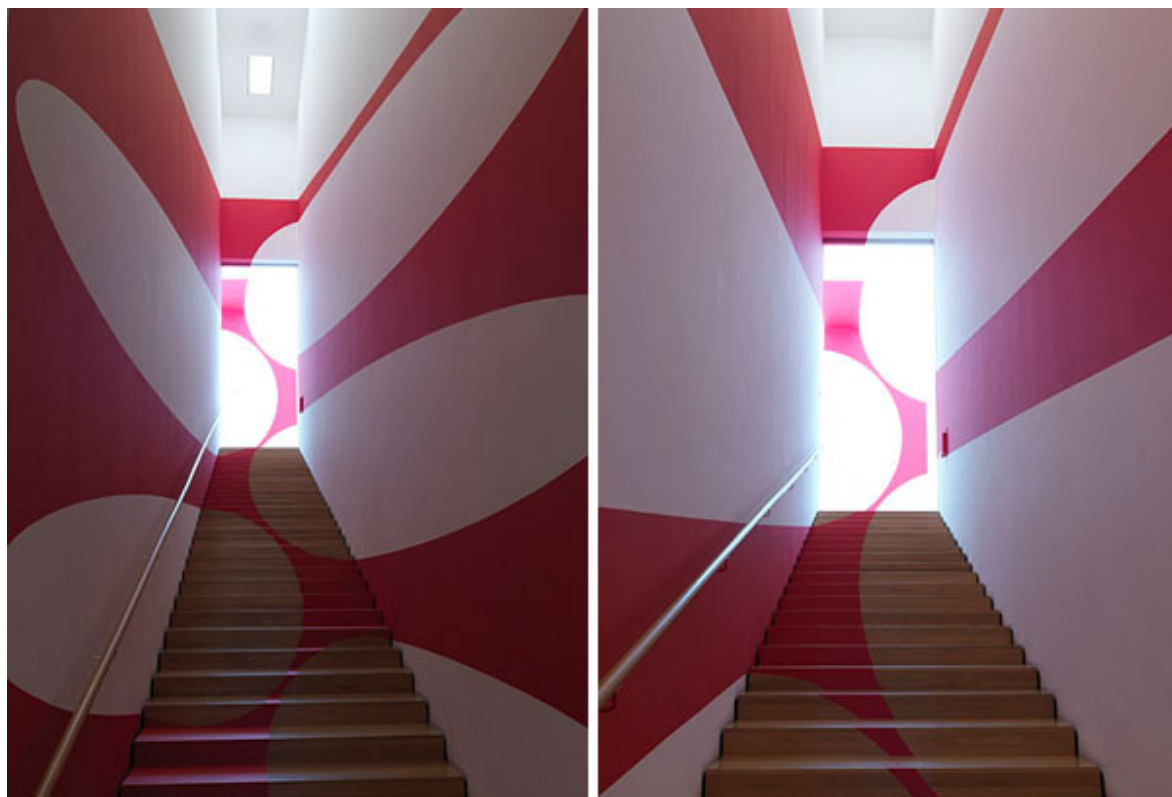





**KAPITAŁ LUDZKI**  
NARODOWA STRATEGIA SPÓJNOŚCI



**UNIA EUROPEJSKA**  
EUROPEJSKI  
FUNDUSZ SPOŁECZNY



# Przykłady anamorfoz refleksyjnych walcowych



**KAPITAŁ LUDZKI**  
NARODOWA STRATEGIA SPÓJNOŚCI



**UNIA EUROPEJSKA**  
EUROPEJSKI  
FUNDUSZ SPOŁECZNY

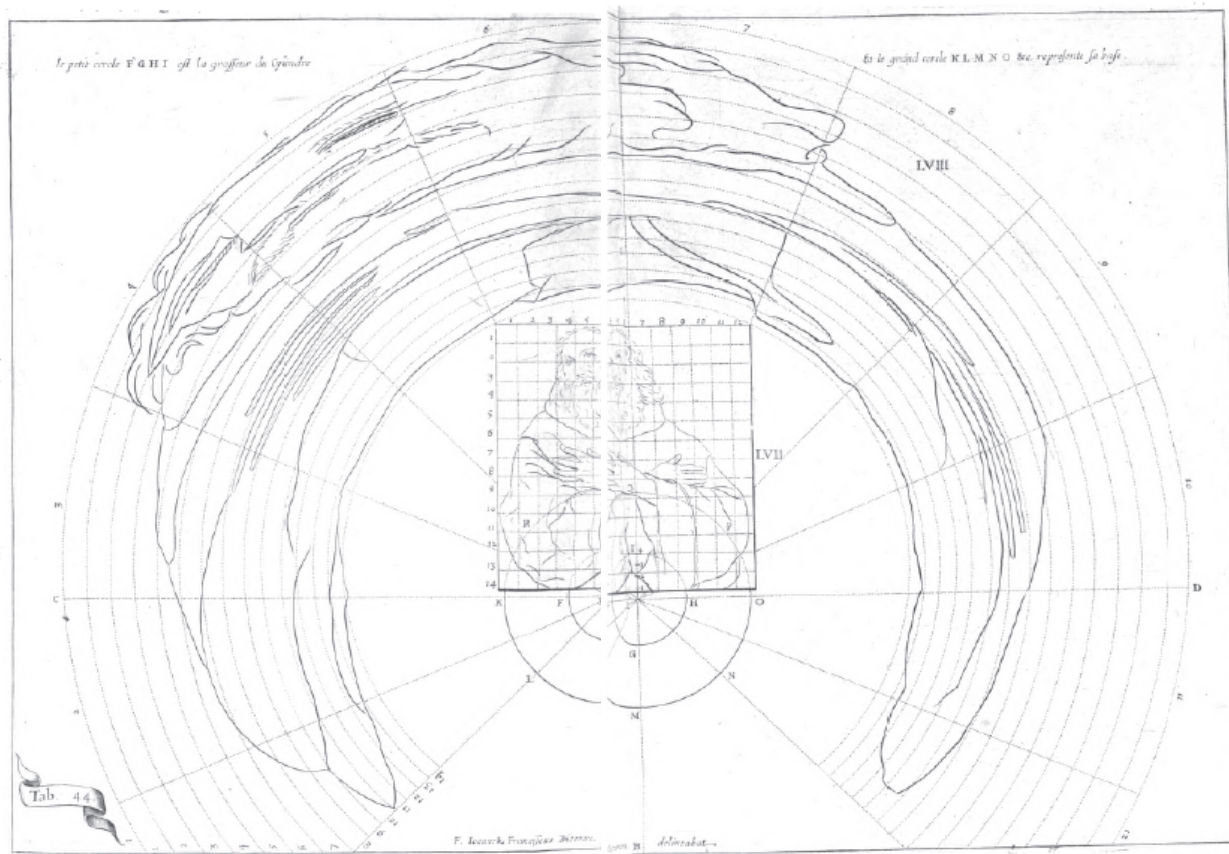



**KAPITAŁ LUDZKI**  
NARODOWA STRATEGIA SPÓJNOŚCI



**UNIA EUROPEJSKA**  
EUROPEJSKI  
FUNDUSZ SPOŁECZNY



# Istvan Orosz





**KAPITAŁ LUDZKI**  
NARODOWA STRATEGIA SPÓJNOŚCI



**UNIA EUROPEJSKA**  
EUROPEJSKI  
FUNDUSZ SPOŁECZNY



# Istvan Orosz







**KAPITAŁ LUDZKI**  
NARODOWA STRATEGIA SPÓJNOŚCI



**UNIA EUROPEJSKA**  
EUROPEJSKI  
FUNDUSZ SPOŁECZNY



# Istvan Orosz





**KAPITAŁ LUDZKI**  
NARODOWA STRATEGIA SPÓJNOŚCI



**UNIA EUROPEJSKA**  
EUROPEJSKI  
FUNDUSZ SPOŁECZNY



# Istvan Orosz







**KAPITAŁ LUDZKI**  
NARODOWA STRATEGIA SPÓJNOŚCI



**UNIA EUROPEJSKA**  
EUROPEJSKI  
FUNDUSZ SPOŁECZNY



# Przykłady anamorfoz refleksyjnych stożkowych



**KAPITAŁ LUDZKI**  
NARODOWA STRATEGIA SPÓJNOŚCI



**UNIA EUROPEJSKA**  
EUROPEJSKI  
FUNDUSZ SPOŁECZNY



# Istvan Orosz

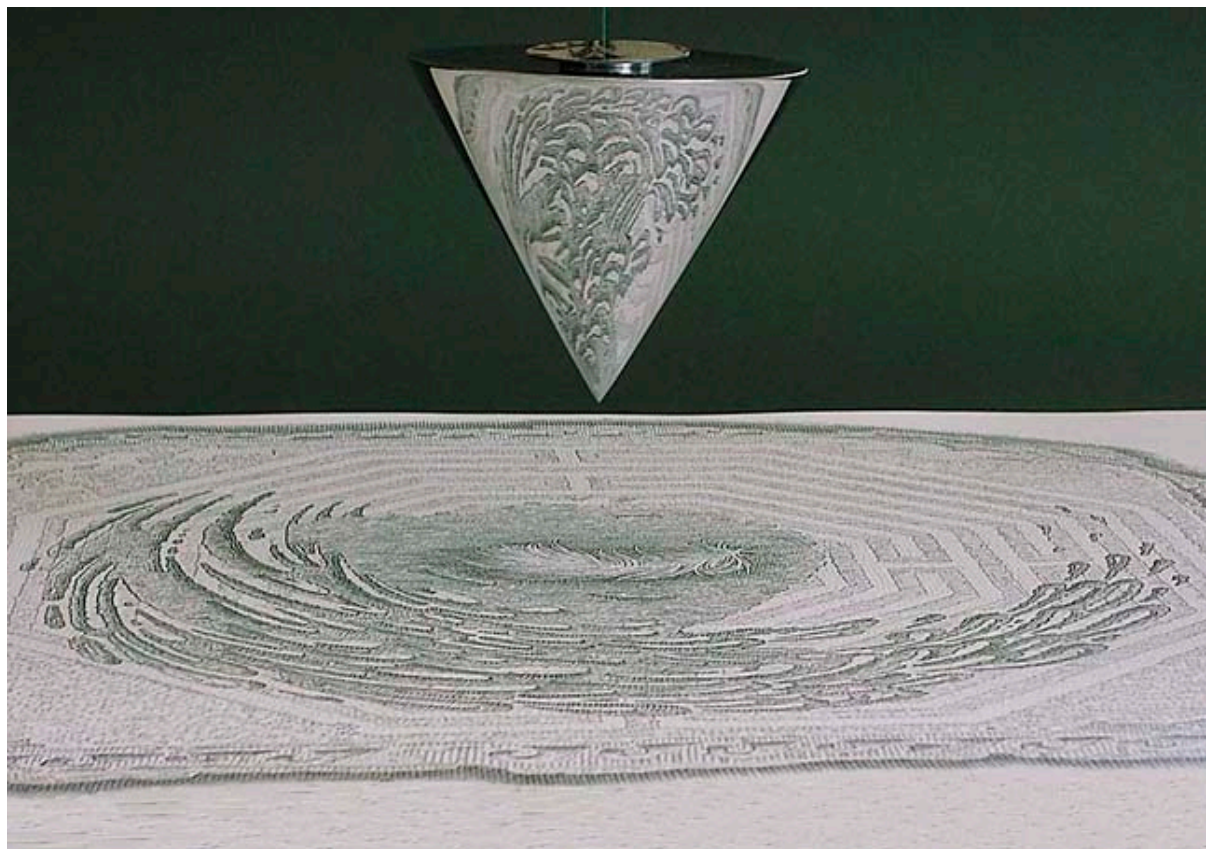



**KAPITAŁ LUDZKI**  
NARODOWA STRATEGIA SPÓJNOŚCI



**UNIA EUROPEJSKA**  
EUROPEJSKI  
FUNDUSZ SPOŁECZNY



# P. Mercier Pinxt. C. Spooner Fecit





**KAPITAŁ LUDZKI**  
NARODOWA STRATEGIA SPÓJNOŚCI



**UNIA EUROPEJSKA**  
EUROPEJSKI  
FUNDUSZ SPOŁECZNY



# Przykłady anamorfoz refleksyjnych ....



**KAPITAŁ LUDZKI**  
NARODOWA STRATEGIA SPÓJNOŚCI



**UNIA EUROPEJSKA**  
EUROPEJSKI  
FUNDUSZ SPOŁECZNY



# Hans Hamngren







**KAPITAŁ LUDZKI**  
NARODOWA STRATEGIA SPÓJNOŚCI



**UNIA EUROPEJSKA**  
EUROPEJSKI  
FUNDUSZ SPOŁECZNY







**KAPITAŁ LUDZKI**  
NARODOWA STRATEGIA SPÓJNOŚCI



**UNIA EUROPEJSKA**  
EUROPEJSKI  
FUNDUSZ SPOŁECZNY



# Hansa Hamngrena





**KAPITAŁ LUDZKI**  
NARODOWA STRATEGIA SPÓJNOŚCI



**UNIA EUROPEJSKA**  
EUROPEJSKI  
FUNDUSZ SPOŁECZNY



# Istvan Orosz

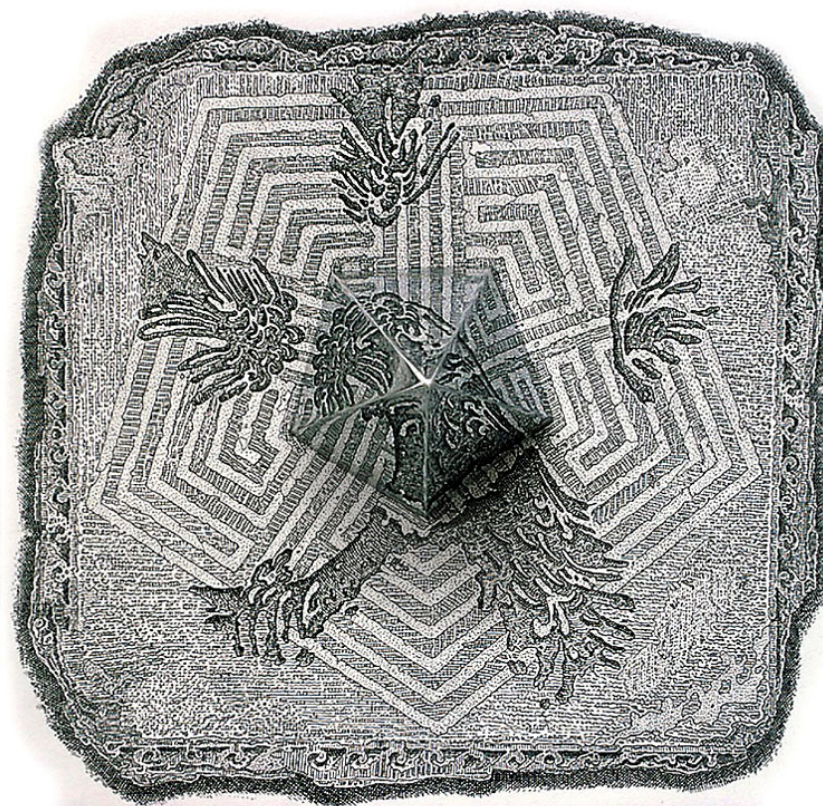



KAPITAŁ LUDZKI  
NARODOWA STRATEGIA SPÓJNOŚCI



UNIA EUROPEJSKA  
EUROPEJSKI  
FUNDUSZ SPOŁECZNY



# Francesco De Comit 

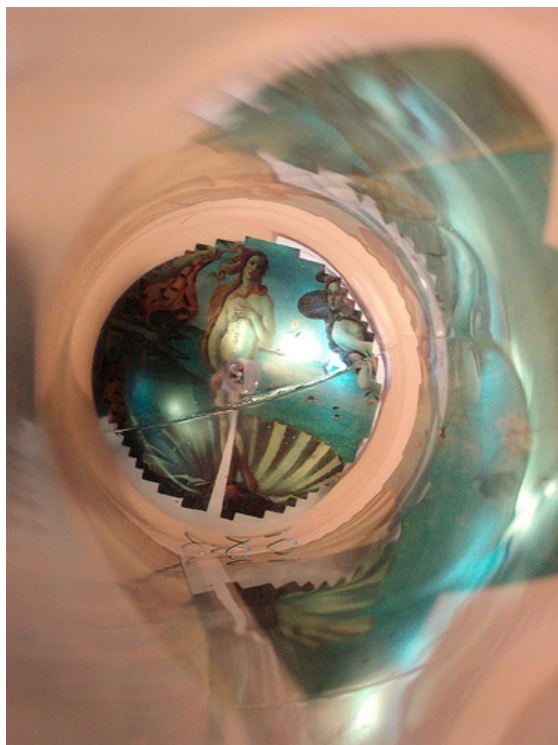





**KAPITAŁ LUDZKI**  
NARODOWA STRATEGIA SPÓJNOŚCI



**UNIA EUROPEJSKA**  
EUROPEJSKI  
FUNDUSZ SPOŁECZNY



# Francesco De Comit 

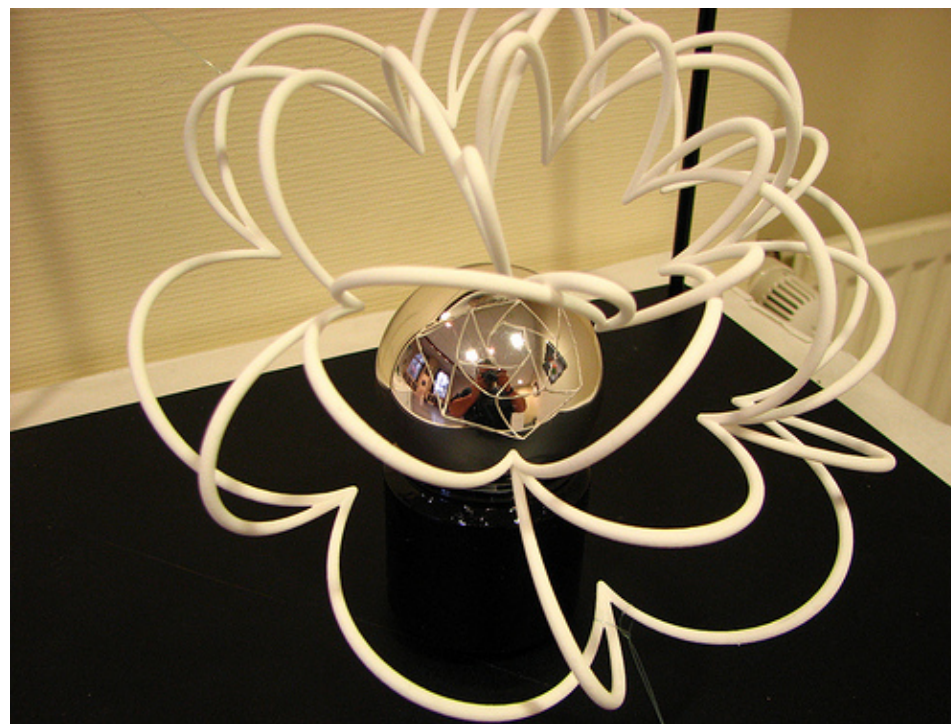





# Zastosowania?

- wzornictwo przemysłowe
- architektura
- projektowanie ogrodów
- reklama
- warsztaty z dziećmi



**KAPITAŁ LUDZKI**  
NARODOWA STRATEGIA SPÓJNOŚCI



**UNIA EUROPEJSKA**  
EUROPEJSKI  
FUNDUSZ SPOŁECZNY



# Dziękuję za uwagę



# Bibliografia

- [1] Alberti L. B. O malarstwie, Wrocław 1963.
- [2] Baltrusaitis J., Anamorfozy, Gdańsk, 2009.
- [3] Bartel K., Perspektywa malarska, tom II, Warszawa, 1958.
- [4] Białostocki J., Albrecht Durer jako pisarz i teoretyk sztuki, Wrocław, 1965.
- [5] Kemp M., The Science of Art: Optical Themes in Western Art from Brunelleschi to Seurat, Yale, 1990.
- [6] Massey L., Picturing Space, Displacing Bodies, Anamorphosis in Early Modern Theories of Perspective, Pennsylvania, 2007.
- [7] Panofsky E., Perspektywa jako „forma symboliczna”, Warszawa, 2008.
- [8] Zdziarski A, Pałka A., Limaçon of Pascal as an Anamorphic Image of a Circle, The Journal of Polish Society for Geometry and Engineering Graphics, No22, 2011.
- [9] Zdziarski A., Deformation Nets for the Reflective Cylindrical Anamorphs, , The Journal of Polish Society for Geometry and Engineering Graphics, No22, 2011.



**KAPITAŁ LUDZKI**  
NARODOWA STRATEGIA SPÓJNOŚCI



**UNIA EUROPEJSKA**  
EUROPEJSKI  
FUNDUSZ SPOŁECZNY



Projekt współfinansowany przez Unię Europejską w ramach Europejskiego Funduszu Społecznego

# Ilustracje ze stron

1. [pixsblog.com](http://pixsblog.com)
2. [anamorphicart.files.wordpress.com](http://anamorphicart.files.wordpress.com)
3. autor na podstawie prac Albertiego i Leonarda da Vinci
4. [anamorphicart.wordpress.com](http://anamorphicart.wordpress.com)
5. Hans Holbein, Ambasadorowie, 1533, Londyn, National Gallery
6. [lifl.fr](http://lifl.fr)
7. [www.exploramuseum.de](http://www.exploramuseum.de)
- 8 Jurgis Baltrusaitis „Anamorfizy”
9. [rense.com](http://rense.com)
10. [anamorphosis.com](http://anamorphosis.com)
11. [anamorphosis.com](http://anamorphosis.com)
12. [latander.livejournal.com/216413.html](http://latander.livejournal.com/216413.html)
13. [anamorphicart.wordpress.com](http://anamorphicart.wordpress.com)
14. Jurgis Baltrusaitis „Anamorfizy”
15. [Rymoillusions.com](http://Rymoillusions.com)

